

ANNUAL REPORT

2017

CITY OF BROOK PARK, OHIO

COMPREHENSIVE ANNUAL FINANCIAL REPORT
FOR THE YEAR ENDED DECEMBER 31, 2017

City of Brook Park, Ohio

**Comprehensive Annual Financial Report
For the Year Ended December 31, 2017**

Issued by: Finance Department

Gregory M. Cingle, CPA, Finance Director

Martin S. Healy, Assistant Finance Director

This page is intentionally left blank

INTRODUCTORY SECTION

City of Brook Park, Ohio
Comprehensive Annual Financial Report
For the Year Ended December 31, 2017
Table of Contents

Page

I. Introductory Section

Table of Contents	i
Letter of Transmittal	v
GFOA Certificate of Achievement	x
Organizational Chart-Departments	xi
City of Brook Park Elected Officials	xii

II. Financial Section

Independent Auditor’s Report.....	1
Management’s Discussion and Analysis.....	5
Basic Financial Statements:	
Government-wide Financial Statements:	
Statement of Net Position.....	17
Statement of Activities.....	18
Fund Financial Statements:	
Balance Sheet – Governmental Funds	19
Reconciliation of Total Governmental Fund Balances To Net Position of Governmental Activities.....	20
Statement of Revenues, Expenditures and Changes in Fund Balances – Governmental Funds.....	21
Reconciliation of the Statement of Revenues, Expenditures and Changes in Fund Balances of Governmental Funds to the Statement of Activities	22
Statement of Revenues, Expenditures and Changes in Fund Balance – Budget (Non-GAAP Budgetary Basis) and Actual:	
General Fund	23
Statement of Net Position – Proprietary Fund	24

City of Brook Park, Ohio
Comprehensive Annual Financial Report
For the Year Ended December 31, 2017
Table of Contents

Page

II. Financial Section (continued)

Statement of Revenues, Expenses and Changes in Net Position – Proprietary Fund	25
Statement of Cash Flows – Proprietary Fund	26
Statement of Fiduciary Net Position – Fiduciary Fund.....	27
Notes to the Basic Financial Statements.....	29

Required Supplementary Information:

Schedule of the City’s Proportionate Share of the Net Pension Liability	73-74
Schedule of City Contributions.....	75-76
Schedule of Funding Progress OPEB.....	77
Notes to the Required Supplementary Information.....	78

Combining Statements and Individual Fund Schedules:

Combining Statements: Non-Major Governmental Funds:

Fund Descriptions	79
Combining Balance Sheet – Non-Major Governmental Funds.....	81
Combining Statement of Revenues, Expenditures and Changes in Fund Balances – Non-Major Governmental Funds	82
Combining Balance Sheet – Non-Major Special Revenue Funds.....	83
Combining Statement of Revenues, Expenditures and Changes in Fund Balances – Non-Major Special Revenue Funds	86

Combining Statements – Agency Funds:

Fund Descriptions	88
Combining Statement of Assets and Liabilities Agency Funds	89
Combining Statement of Changes in Assets and Liabilities Agency Funds	90

City of Brook Park, Ohio

Comprehensive Annual Financial Report For the Year Ended December 31, 2017

Table of Contents

Page

II. Financial Section (continued)

Individual Fund Schedules of Revenues, Expenditures and Changes in Fund

Balances – Budget (Non-GAAP Budgetary Basis) and Actual:

Major and Non-Major Funds:

General Fund.....	92
Capital Improvements Fund.....	101
Street Maintenance Fund.....	103
State Highway Fund.....	104
Permissive Tax Fund.....	105
Economic Development Fund.....	106
Brook Park Road Corridor Fund.....	107
CDBG Fund.....	108
Special Recreation Fund.....	109
Law Enforcement Fund.....	110
DWI Enforcement and Education Fund.....	111
Federal Forfeiture Fund.....	112
Community Diversion Fund.....	113
Retiree Accrued Benefits Fund.....	114
Continuing Training Program Fund.....	115
FEMA Fund.....	116
Police Pension Fund.....	117
Fire Pension Fund.....	118
Southwest General Health Center Fund.....	119
General Obligation Fund.....	120
Self-Insured Medical Benefits.....	121

III. Statistical Section

Contents.....	S1
Net Position by Component – Last Ten Fiscal Years.....	S2
Changes in Net Position– Last Ten Fiscal Years.....	S3
Fund Balances, Governmental Funds – Last Ten Fiscal Years.....	S5
Changes in Fund Balances, Governmental Funds – Last Ten Fiscal Years.....	S6
Assessed Valuations and Estimated True Values – Last Ten Years.....	S8
Property Tax Rates – Direct and Overlapping Governments – (Per \$1,000 of Assessed Valuation) – Last Ten Years.....	S9

City of Brook Park, Ohio

Comprehensive Annual Financial Report For the Year Ended December 31, 2017

Table of Contents

Page

III. Statistical Section (continued)

Real Property Tax Levies and Collections – Last Ten Years	S10
Tangible Personal Property Tax Levies and Collections – Last Ten Years.....	S11
Principal Taxpayers – Real Estate Tax – 2016 and 2007.....	S12
Municipal Income Tax Revenues by Source – Last Ten Years	S13
Ratio of Outstanding Debt to Total Personal Income and Debt per Capita – Last Ten Years	S14
Ratio of Net General Bonded Debt to Assessed Value and Net Bonded Debt Per Capita – Last Ten Years.....	S15
Computation of Direct and Overlapping Debt.....	S16
Legal Debt Margin – Last Ten Fiscal Years.....	S17
Principal Employers – Current Year and 2007	S18
Demographic and Economic Statistics – Last Ten Years	S19
Full Time Employees by Function/Program – Last Ten Years	S20
Operating Indicators by Function/Program – Last Ten Years	S21
Capital Assets Statistics by Function/Program – Last Ten Years	S23

City of Brook Park

Finance Department

Gregory M. Cingle
Finance Director

Martin S. Healy
Assistant Finance Director

June 8, 2018

To the Honorable Mayor and Members of City Council,
And Citizens of Brook Park, Ohio:

State law requires that all general-purpose local governments publish within six months of the close of each fiscal year a complete set of financial statements presented in conformity with Generally Accepted Accounting Principles (GAAP) and audited in accordance with Generally Accepted Auditing Standards (GAAS) by a firm of licensed certified public accountants. Pursuant to that requirement, we hereby issue the Comprehensive Annual Financial Report (CAFR) of the city of Brook Park (City) for the fiscal year ended December 31, 2017.

This report consists of management's representations concerning the finances of the City. Consequently, management assumes full responsibility for the completeness and reliability of all of the information presented in this report. To provide a reasonable basis for making these representations, management of the City has established a comprehensive internal control framework that is designed to both compile sufficient reliable information for the preparation of the City's financial statements in conformity with GAAP and protect the government's assets from loss, theft or misuse. Since the cost of internal controls should not outweigh their benefits, the City's comprehensive framework of internal controls has been designed to provide reasonable rather than absolute assurance that the financial statements will be free from material misstatement. As management, we assure that, to the best of our knowledge and belief, this financial report is complete and reliable in all material respects.

The City's financial statements have been audited by James G. Zupka, C.P.A., Inc. The goal of the independent audit was to provide reasonable assurance that the financial statements of the City for the fiscal year ended December 31, 2017, are free of material misstatement. The independent audit involved examining, on a test basis, evidence supporting the amounts and disclosures in the financial statements, assessing the accounting principles used and significant estimates made by management and evaluating the overall financial statement presentation. The independent auditor concluded, based upon the audit, that there was a reasonable basis for rendering an unmodified opinion on the financial statements of the City for the fiscal year ended December 31, 2017, and that the financial statements are fairly presented in conformity with GAAP. The report of the independent auditor is presented as the first component of the financial section of this report.

The requirements of GAAP necessitate that management provide a narrative introduction, overview and analysis to accompany the basic financial statements in the form of Management's Discussion and Analysis (MD&A). This Letter of Transmittal is designed to complement the City's MD&A and should be read in conjunction with it. The MD&A can be found immediately following the report of the independent auditors.

Profile of the Government

The City, incorporated in 1967, is located in the Southwest portion of Cuyahoga County, 13 miles from Downtown Cleveland, with the cities of Parma to the east, Berea to the west and Middleburg Heights to the south. Brook Park is an easily accessible suburban community that abuts Cleveland Hopkins Airport on the Northwest boundary and has ready access to Interstates 71 and 480 and the Ohio Turnpike. With an excellent combination of residential, commercial and industrial areas that provide tax support, the City is able to finance the building of excellent administrative, recreational and service facilities as well as provide a wide variety of municipal services, such as police and fire services, street services, sewer services and recreation services.

The City operates under a mayor-council form of government. The mayor, designated by the charter as the chief executive officer of the City, is elected to serve a four-year term. The mayor has the power to appoint, promote, discipline, transfer, reduce or remove any employee of the City, except those elected, those who work for an elected official and those whose terms of office are set by the charter. Legislative authority is vested in an eight-member council. The council consists of a president, three council members elected at-large and four council members elected by ward. Council members are elected to serve a two-year term. Each member of council has a right to vote, except for the president, who may vote only in the event of a tie.

The mayor is entitled to a seat on council but has no voting rights. The mayor may veto any legislation passed by council. A veto may be overridden by a two-thirds vote of all members of council. The council fixes compensation of City officials and employees and enacts ordinances and resolutions relating to City services, tax levies, appropriations, indebtedness, the licensing of regulated businesses and trades and other municipal purposes.

Other elected officials include the finance director and law director, each of whom serve four-year terms.

Detailed provisions for the City's budget, tax levies and appropriations are set forth in the Ohio Revised Code and the charter. With the assistance of the finance director, the mayor is required to submit to council an estimate of the revenues and expenditures of the City for the succeeding fiscal year. The mayor submits to council an appropriation ordinance budget for the next succeeding fiscal year based on the annual estimate. Council is required to adopt said ordinance in its original form or with those revisions as it may find proper within 90 days of the beginning of the fiscal year.

The City maintains budgetary control on a non-GAAP basis by fund and within each fund by department at major object levels, which include personal services, travel and education, contractual services, supplies and materials, other expenditures, capital outlay, debt service and transfers. For management purposes, the major object level is further defined with budgeted amounts not to exceed the aggregate appropriated by council.

Budgetary control is maintained by an encumbrance of purchase commitment amounts prior to the release of purchase orders to vendors. Requisitions for the expenditure of monies are submitted to the mayor for approval and preparation of a purchase order. The purchase order is forwarded to the finance director's office for certification of the availability of funds. Once certified, the estimated expenditure is encumbered against the available appropriation. Unencumbered appropriations lapse at the end of each year. The City's accounting system provides interim financial reports that detail year-to-date expenditures plus encumbrances versus the original appropriations plus or minus any additional approved appropriations. The report permits the officials of the City to ascertain the status of a department's appropriations at any time during the year.

Factors Affecting Financial Condition

I. Economic Conditions and Outlook. In general, the U.S. economic growth continues at a moderate pace. Some of the factors are as follows:

- The 2017 calendar year realized job growth of over 2 million jobs. Unemployment was still at a 17-year low of 4.1 percent.
- The Federal Reserve raised the federal funds rate three times in 2017 from .75% to 1.50%.
- Oil prices continued to increase in 2017.
- Many of the major market indexes realized healthy gains in 2017.

II. Local Economic Activity. The City continues to exercise significant energy to sustain its existing economic base and pursue new business opportunities.

- Work continues with the cities of Cleveland, Parma, Berea and Olmsted Falls to create an aerotropolis centered around Cleveland Hopkins Airport. The goal of the project is to enhance and generate new economic activity within designated areas of each of the communities.
- Regency Construction Services has located their new facility on Engle Rd. They are a full service commercial construction company that will employ approximately 40 people.
- We would like to also welcome the Ohio Hospitality Group to Brook Park. They have recently purchased the Airport Inn on Brookpark Rd.
- Varbros Industries is constructing a 32,000 sq. ft. production facility at an estimated cost of \$1.9 million dollars. Twelve new jobs are planned.
- As a member of the First Suburbs Development Coalition (FSDC), Brook Park will continue to work toward finding meaningful programs that can be administered by the FSDC. Capitalizing on recent changes in state law, each of the 16 member FSDC communities banded together to create the Advanced Energy District (AED) to provide assistance for financing energy-saving improvements for commercial and industrial businesses located within the AED.

The above initiatives are imperative to the City's economic development strategy and long-term success. Each of these projects will help to enhance the City's ability to attract additional investment into the community.

III. Major Economic Initiatives. The City continued to focus on business retention, redevelopment opportunities, infrastructure improvements and prospecting for new business investment in the community.

Retention Activity:

We remain focused on the events surrounding Ford Motor Company and NASA Glenn:

- **Ford Motor Company:** The City is working closely with the leadership at Ford Motor Company to develop approximately 250 acres of unused land and buildings at the Brook Park location. The goal is to attract advanced technological businesses or a healthcare center.

- **NASA Glenn (“Glenn”):** The federal budget approved by Congress included continuing funding for Glenn. A new \$47 million facility will be built on the western side of the 350-acre headquarters in Brook Park. The facility will focus on aerospace communications.

Glenn will continue to play a leading role in developing Gateway, a platform expected to enter lunar orbit in 2022 and stay there for 15 to 20 years. Among other tasks, Glenn will develop the platform's power and propulsion element. Glenn also has key duties in developing Orion, which will take people to Gateway and beyond. These programs will benefit other NASA science and exploration missions. Employment and subcontractor levels are projected to remain stable.

Redevelopment Opportunities:

- Since acquiring the north side of Brookpark Rd. from the City of Cleveland in 1999, there has been over \$47 million of private and public funding invested into this area. The City will continue to meet with building owners and developers to find creative opportunities for new projects along this important corridor.
- The City continues to review the 2012 Master Plan to obtain ideas for redevelopment, land use and zoning updates.
- The City currently owns 34 acres available in the Opportunity Zone that is available for sale and development.

Infrastructure:

- The Snow Rd. resurfacing project began in 2017. Approximately \$3 million was invested, with the majority of the funding coming from a grant awarded by ODOT.
- The 2017 sidewalk repair program commenced.
- In 2017, the West 150th St. sanitary sewer improvement project (Phase IV) was substantially completed.
- Reconstruction of Bowfin Blvd., Calvin Dr., Middlebrook Blvd. and Sylvia Dr. began in 2017.

The above initiatives are imperative to the City’s economic development strategy and long-term success. Each of these projects will help enhance the City’s ability to attract additional investment into the community.

Cash Management Policies and Practices

Cash management is a vital component of the City’s overall financial strategy. Under the direction of the finance director, the City maintains an aggressive cash management program. Major considerations are timing of cash flows necessary to pay City liabilities and available interest rates. As City funds become available, they are invested immediately in short-term certificates of deposit or other securities authorized by state statutes. Interest earnings are allocated to funds based on the requirements of the Ohio Constitution and state statutes. All deposits and investments are covered by the Ohio Pooled Collateral System (OPCS. OPCS requires the total fair value of the securities pledged to be 102 percent of the deposits being secured or a rate set by the Treasurer of State.

Risk Management

The City has contracted with Wichert Insurance Company to negotiate property, general liability, boiler and machinery, automobile, law enforcement, public officials and umbrella insurance for the City. Medical insurance is provided for full-time employees and their families. The plan is fully-funded and administered by a third party administrator. The state of Ohio provides workers' compensation coverage for employees of the City.

Awards and Acknowledgements

Certificate of Achievement. The Government Finance Officers Association (GFOA) awarded a Certificate of Achievement for Excellence in Financial Reporting to the City for its CAFR for the fiscal year ended December 31, 2016. The Certificate of Achievement is a prestigious national award that recognizes conformance with the highest standards for preparation of state and local government financial reports.

In order to be awarded a Certificate of Achievement, the City published an easily readable and efficiently organized CAFR. This report conformed to program standards and satisfied both GAAP and applicable legal requirements.

The Certificate of Achievement is valid for a period of only one year. The City has received a Certificate of Achievement for the last 26 years. We believe that our current CAFR continues to meet the requirements for the Certificate of Achievement, and we are submitting it to the GFOA to determine its eligibility for another certificate.

Acknowledgement. The Finance Department, with the efficient and dedicated service of its entire staff, prepared this CAFR. We would like to express special appreciation to the independent accounting firm of James G. Zupka, CPA, Inc. for their assistance in preparing this report. In addition, we would like to thank the Mayor and each member of Brook Park City Council for their support, which has allowed the Finance Department to operate at the level that the residents of the City demand and deserve.

Respectfully submitted,

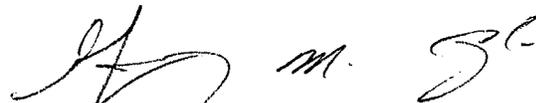
A handwritten signature in black ink, appearing to read 'G. M. Cingle', is written over the printed name below.

Gregory M. Cingle, CPA, MBA
Finance Director



Government Finance Officers Association

**Certificate of
Achievement
for Excellence
in Financial
Reporting**

Presented to

**City of Brook Park
Ohio**

For its Comprehensive Annual
Financial Report
for the Fiscal Year Ended

December 31, 2016

Christopher P. Morill

Executive Director/CEO

City of Brook Park Administration

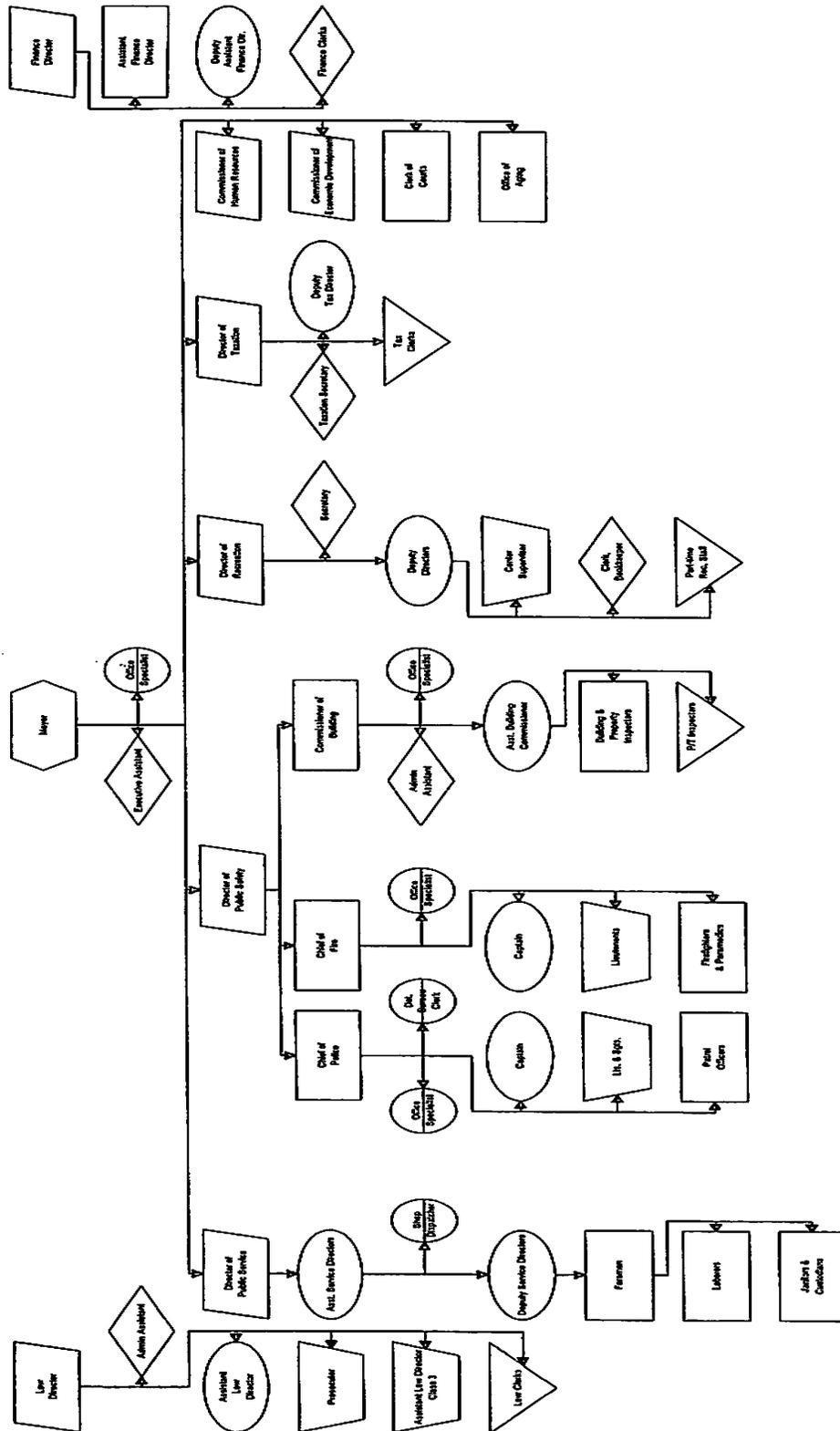

City of Brook Park, Ohio

Elected Officials

December 31, 2017

Mayor	Thomas J. Coyne
Council Member – President	Jim Astorino
Council Member – At-Large	Carl J. Burgio
Council Member – At-Large	Rachel J. McDonnell
Council Member – At-Large	Richard A. Salvatore
Council Member – Ward 1	Tom Troyer
Council Member – Ward 2	Jim Mencini
Council Member – Ward 3	Jan Powers
Council Member – Ward 4	Richard D. Scott
Finance Director	Gregory M. Cingle
Law Director	Carol Horvath

FINANCIAL SECTION

JAMES G. ZUPKA, C.P.A., INC.

Certified Public Accountants

5240 East 98th Street

Garfield Hts., Ohio 44125

Member American Institute of Certified Public Accountants

(216) 475 - 6136

Ohio Society of Certified Public Accountants

INDEPENDENT AUDITOR'S REPORT

To the Members of City Council
City of Brook Park
Brook Park, Ohio

The Honorable Dave Yost
Auditor of State
State of Ohio

Report on the Financial Statements

We have audited the accompanying financial statements of the governmental activities, each major fund, and the aggregate remaining fund information of the City of Brook Park, Cuyahoga County, Ohio, (the City) as of and for the year ended December 31, 2017, and the related notes to the financial statements, which collectively comprise the City's basic financial statements as listed in the table of contents.

Management's Responsibility for the Financial Statements

Management is responsible for the preparation and fair presentation of these financial statements in accordance with accounting principles generally accepted in the United States of America; this includes the design, implementation, and maintenance of internal control relevant to the preparation and fair presentation of financial statements that are free from material misstatement, whether due to fraud or error.

Auditor's Responsibility

Our responsibility is to express opinions on these financial statements based on our audit. We conducted our audit in accordance with auditing standards generally accepted in the United States of America and the standards applicable to financial audits contained in *Government Auditing Standards*, issued by the Comptroller General of the United States. Those standards require that we plan and perform the audit to obtain reasonable assurance about whether the financial statements are free from material misstatement.

An audit involves performing procedures to obtain audit evidence about the amounts and disclosures in the financial statements. The procedures selected depend on the auditor's judgment, including the assessment of the risks of material misstatement of the financial statements, whether due to fraud or error. In making those risk assessments, the auditor considers internal control relevant to the City's preparation and fair presentation of the financial statements in order to design audit procedures that are appropriate in the circumstances, but not for the purpose of expressing an opinion on the effectiveness of the City's internal control. Accordingly, we express no such opinion. An audit also includes evaluating the appropriateness of accounting policies used and the reasonableness of significant accounting estimates made by management, as well as evaluating the overall presentation of the financial statements.

We believe that the audit evidence we have obtained is sufficient and appropriate to provide a basis for our audit opinions.

Opinions

In our opinion, the financial statements referred to above present fairly, in all material respects, the respective financial position of the governmental activities, each major fund, and the aggregate remaining fund information of the City of Brook Park as of December 31, 2017, and the respective changes in financial position, and, where applicable, cash flows thereof and the budgetary comparison for the General Fund for the year then ended in accordance with accounting principles generally accepted in the United States of America.

Other Matters

Required Supplementary Information

Accounting principles generally accepted in the United States of America require that the Management's Discussion and Analysis and Schedules of Net Pension Liabilities and Pension Contributions, as listed in the table of contents, be presented to supplement the basic financial statements. Such information, although not a part of the basic financial statements, is required by the Governmental Accounting Standards Board, who considers it to be an essential part of financial reporting for placing the basic financial statements in an appropriate operational, economic, or historical context. We have applied certain limited procedures to the required supplementary information in accordance with auditing standards generally accepted in the United States of America, which consisted of inquiries of management about the methods of preparing the information and comparing the information for consistency with management's responses to our inquiries, the basic financial statements, and other knowledge we obtained during our audit of the basic financial statements. We do not express an opinion or provide any assurance on the information because the limited procedures do not provide us with sufficient evidence to express an opinion or provide any assurance.

Other Information

Our audit was conducted for the purpose of forming opinions on the financial statements that collectively comprise the City's basic financial statements. The introductory section, combining and individual nonmajor fund financial statements and schedules, and statistical section are presented for purposes of additional analysis and are not a required part of the basic financial statements.

The combining and individual nonmajor fund financial statements and schedules are the responsibility of management and were derived from and relate directly to the underlying accounting and other records used to prepare the basic financial statements. Such information has been subjected to the auditing procedures applied in the audit of the basic financial statements and certain additional procedures, including comparing and reconciling such information directly to the underlying accounting and other records used to prepare the basic financial statements or to the basic financial statements themselves, and other additional procedures in accordance with auditing standards generally accepted in the United States of America. In our opinion, the combining and individual nonmajor fund financial statements and schedules are fairly stated in all material respects in relation to the basic financial statements as a whole.

The introductory and statistical sections have not been subjected to the auditing procedures applied in the audit of the basic financial statements and, accordingly, we do not express an opinion or provide any assurance on them.

Other Reporting Required by *Government Auditing Standards*

In accordance with *Government Auditing Standards*, we have also issued our report dated June 8, 2018, on our consideration of the City's internal control over financial reporting and on our tests of its compliance with certain provisions of laws, regulations, contracts, and grant agreements and other matters. The purpose of that report is to describe the scope of our testing of internal control over financial reporting and compliance and the results of that testing, and not to provide an opinion on internal control over financial reporting or on compliance. That report is an integral part of an audit performed in accordance with *Government Auditing Standards* in considering the City's internal control over financial reporting and compliance.



James G. Zupka, CPA, Inc.
Certified Public Accountants

June 8, 2018

This page is intentionally left blank.

City of Brook Park, Ohio

Management's Discussion and Analysis (Unaudited)

For the Year Ended December 31, 2017

The discussion and analysis of the City of Brook Park's (the City) financial performance provides an overall review of the City's financial activities for the year ended December 31, 2017. The intent of this discussion and analysis is to look at the City's financial performance as a whole. Readers are encouraged to consider this information in conjunction with the additional information contained in the financial statements and the notes thereof.

Financial Highlights

Key financial highlights for 2017 are:

- Revenue from municipal income and other taxes totaled \$19,774,881.
- Total assets and deferred outflows of resources increased by \$10,072,553 or a 9.02 percent increase from 2016.
- Total net position increased by \$1,293,521 or a 1.83 percent increase from 2016.
- Total capital assets increased by \$8,523,266 or a 10.97 percent increase from 2016.
- Total liabilities and deferred inflows of resources increased by \$8,779,012. This was a 21.47 percent increase from 2016, which is mainly attributed to the issuance of the bond and new capital leases.
- At the end of the current fiscal year, the City's governmental funds reported combined ending fund balances of \$19,785,690 an increase of \$611,822 in comparison with the prior year's amount. Approximately 30.47 percent of this total amount, or \$6,028,519, is available for spending at the government's discretion (unassigned fund balance) without externally or internally imposed constraints.
- At the end of the current fiscal year, the General Fund's unassigned fund balance was \$6,028,519, or 31.93 percent of General Fund expenditures (not including other financing uses).

Using This Comprehensive Annual Financial Report (CAFR)

This annual report consists of a series of financial statements and notes to those statements. These statements are prepared and organized so the reader can understand the City both financially and operationally. The statements proceed to provide an increasingly detailed look at our specific financial condition.

The *Statement of Net Position* and *Statement of Activities* provide information about the activities of the whole City, presenting both an aggregate view of the City's finances and long-term view of those assets. Major fund financial statements provide the next level of detail. For governmental funds, these statements tell how services were financed in the short-term and what dollars remain for future spending. The fund financial statements also look at the City's most significant funds, with all other nonmajor funds presented in total in one column.

City of Brook Park, Ohio

Management's Discussion and Analysis (Unaudited) (continued)

For the Year Ended December 31, 2017

Reporting the City of Brook Park as a Whole

Statement of Net Position and Statement of Activities

While the CAFR contains information about the funds used by the City to provide services to our citizens, the *Statement of Net Position* and the *Statement of Activities* provide a view of the City's monetary transactions and answer the question, "How did the City do financially during 2017?" These statements include all assets, deferred outflows of resources, liabilities, and deferred inflows of resources using the accrual basis of accounting, which is similar to the accounting method used by the private sector. This accounting method takes into account all of the current year's revenues and expenses regardless of when cash is received or paid.

These two statements report the City's net position and the changes in net position. The changes in net position are important because it tells the reader whether the financial position of the City has improved or diminished. When evaluating the overall position of the City, non-financial information should also be considered, such as: changes in the City's tax base, amendments to property and income tax laws, condition of capital assets, etc.

The *Statement of Net Position* and the *Statement of Activities* will include the following governmental activities: police, fire, street maintenance, parks and recreation and general administration. Income taxes, property taxes and state and federal subsidy grants finance most of these activities.

The *Statement of Net Position* and the *Statement of Activities* are divided into the following categories:

- Assets
- Deferred Outflows of Resources
- Liabilities
- Deferred Inflows of Resources
- Net Position (Assets and Deferred Outflows of Resources minus Liabilities and Deferred Inflows of Resources)
- Program Revenues and Expenses
- General Revenues
- Net Position at the Beginning and End of Year

Reporting of the Most Significant Funds of the City of Brook Park

Fund Financial Statements

The presentation of the City's major funds begins on page 19. Fund financial statements provide detailed information about the City's major funds based on the restrictions on the use of monies. The City has established many funds to account for the multitude of services, facilities and infrastructure improvements provided to our residents. However, these fund financial statements focus on the City's most significant funds. In the case of the City, the major funds are the General and Capital Improvements Funds. All of the funds of the City can be divided into three categories: governmental funds, proprietary funds and fiduciary funds.

City of Brook Park, Ohio

Management's Discussion and Analysis (Unaudited) (continued)

For the Year Ended December 31, 2017

Governmental Funds

Governmental funds are used to account for essentially the same functions reported as governmental activities in the government-wide financial statements. However, unlike the government-wide financial statements, governmental fund financial statements focus on near-term inflows and outflows of spendable resources as well as on the balance of spendable resources available at the end of the fiscal year. Such information may be useful in evaluating the near-term financing requirements of a government. These funds are reported using an accounting method called modified accrual accounting, which measures cash and all other financial assets and deferred inflows of resources that can readily be converted to cash. The governmental fund statements provide a detailed short-term view of the City's general government operations and the basic services it provides. Both the *Governmental Funds Balance Sheet* and the *Governmental Funds Statement of Revenues, Expenditures and Changes in Fund Balances* provide a reconciliation to facilitate a comparison between governmental activities (reported in the *Statement of Net Position* and the *Statement of Activities*) and governmental funds.

The City maintains 19 individual governmental funds. Information is presented separately in the *Governmental Funds Balance Sheet* and in the *Governmental Funds Statement of Revenues, Expenditures and Changes in Fund Balances* for the General Fund and Capital Improvements Fund. Data from the other governmental funds are combined into single, aggregated presentations. Individual fund data for each of these nonmajor governmental funds is provided elsewhere in this CAFR in the form of combining statements.

The City adopts an annual appropriated budget for each of its funds. A budgetary comparison statement (non-GAAP budgetary basis) has been provided for each governmental and proprietary fund to demonstrate budgetary compliance.

Proprietary Funds

Internal service funds are an accounting device used to accumulate and allocate costs internally among the various functions of a city. Since this predominately benefits governmental rather than business functions, it has been included within governmental activities in the government-wide financial statements. The City maintains one type of proprietary fund for the self-insurance of health care benefits.

Proprietary funds provide the same type of information as the government-wide financial statements, only in more detail. The proprietary fund financial statements provide separate information for the Internal Service Fund.

The basic proprietary fund financial statements can be found starting on page 24.

Fiduciary Funds

Fiduciary funds are used to account for resources held for the benefit of parties outside the government and are not reflected in the government-wide financial statements because resources are not available to support the City's own programs. The City has only agency funds to report within the fiduciary fund category. Agency funds are reported on a full accrual basis of accounting and only present a statement of fiduciary net position.

City of Brook Park, Ohio

Management's Discussion and Analysis (Unaudited) (continued)

For the Year Ended December 31, 2017

Notes to the Financial Statements

The notes provide additional information that is essential for a full understanding of the data provided in the government-wide and fund financial statements. The notes to the financial statements can be found starting on page 29.

Other information

In addition to the basic financial statements and the accompanying notes, this CAFR also presents certain other information that the City believes readers will find useful. After the notes to the basic financial statements, the required supplementary information and the combining statements, referred to earlier in connection with nonmajor governmental funds, are presented along with individual detailed budgetary comparisons for all nonmajor funds. This information can be found starting on page 73.

The City as a Whole

As noted earlier, the *Statement of Net Position* looks at the City as a whole and can prove to be a useful indicator of the City's financial position. Table 1 provides a summary of the City's net position for 2017 as compared to 2016.

Table 1
Net Position

	<u>2017</u>	<u>2016</u>
ASSETS		
Current and other assets	\$ 28,645,815	\$ 27,176,165
Net pension asset	11,569	13,212
Capital assets, net	<u>86,214,109</u>	<u>77,690,843</u>
Total Assets	<u>114,871,493</u>	<u>104,880,220</u>
DEFERRED OUTFLOWS OF RESOURCES		
Pension	<u>6,841,698</u>	<u>6,760,438</u>
LIABILITIES		
Current and other liabilities	2,227,745	1,212,875
Long-term liabilities:		
Due within one year	1,784,311	1,062,847
Due in more than one year		
Net pension liability	26,569,333	24,270,057
Other amounts	<u>16,038,965</u>	<u>10,798,025</u>
Total Liabilities	<u>46,620,354</u>	<u>37,343,804</u>
DEFERRED INFLOWS OF RESOURCES		
Property taxes	1,677,004	1,618,218
Pension	<u>1,378,067</u>	<u>1,934,391</u>
Total Deferred Inflows of Resources	<u>3,055,071</u>	<u>3,552,609</u>
NET POSITION		
Net investment in capital assets	71,280,520	67,797,950
Restricted	10,698,483	10,094,025
Unrestricted	<u>(9,941,237)</u>	<u>(7,147,730)</u>
Total Net Position	<u>\$ 72,037,766</u>	<u>\$ 70,744,245</u>

City of Brook Park, Ohio

Management's Discussion and Analysis (Unaudited) (continued)

For the Year Ended December 31, 2017

The City has adopted GASB Statement 68, "Accounting and Financial Reporting for Pensions—an Amendment of GASB Statement 27," which significantly revises accounting for pension costs and liabilities. For reasons discussed below, many end users of this financial statement will gain a clearer understanding of the City's actual financial condition by adding deferred inflows related to pension and the net pension liability to the reported net position and subtracting deferred outflows related to pension.

Governmental Accounting Standards Board (GASB) standards are national and apply to all government financial reports prepared in accordance with generally accepted accounting principles. When accounting for pension costs, GASB 27 focused on a funding approach. This approach limited pension costs to contributions annually required by law, which may or may not be sufficient to fully fund each plan's net pension liability. GASB 68 takes an earnings approach to pension accounting; however, the nature of Ohio's statewide pension systems and state law governing those systems requires additional explanation in order to properly understand the information presented in these statements.

Under the standards required by GASB 68, the net pension liability equals the City's proportionate share of each plan's collective:

1. Present value of estimated future pension benefits attributable to active and inactive employees' past service
2. Minus plan assets available to pay these benefits

GASB notes that pension obligations, whether funded or unfunded, are part of the "employment exchange" – that is, the employee is trading his or her labor in exchange for wages, benefits, and the promise of a future pension. GASB noted that the unfunded portion of this pension promise is a present obligation of the government, part of a bargained-for benefit to the employee and should accordingly be reported by the government as a liability since they received the benefit of the exchange. However, the City is not responsible for certain key factors affecting the balance of this liability. In Ohio, the employee shares the obligation of funding pension benefits with the employer. Both employer and employee contribution rates are capped by State statute. A change in these caps requires action of both Houses of the General Assembly and approval of the Governor. Benefit provisions are also determined by State statute. The employee enters the employment exchange with the knowledge that the employer's promise is limited not by contract but by law. The employer enters the exchange also knowing that there is a specific, legal limit to its contribution to the pension system. In Ohio, there is no legal means to enforce the unfunded liability of the pension system *as against the public employer*. State law operates to mitigate/lessen the moral obligation of the public employer to the employee, because all parties enter the employment exchange with notice as to the law. The pension system is responsible for the administration of the plan.

Most long-term liabilities have set repayment schedules or are satisfied through paid time-off or termination payments, i.e. sick and vacation leave. There is no repayment schedule for the net pension liability. As explained above, changes in pension benefits, contribution rates and return on investments affect the balance of the net pension liability and local government. In the event that contributions, investment returns and other changes are insufficient to keep up with required pension payments, State statute does not assign/identify the responsible party for the unfunded portion. Due to the unique nature of how the net pension liability is satisfied, this liability is separately identified within the long-term liability section of the statement of net position.

City of Brook Park, Ohio

Management's Discussion and Analysis (Unaudited) (continued)

For the Year Ended December 31, 2017

In accordance with GASB 68, the City's statements prepared on an accrual basis of accounting include an annual pension expense for their proportionate share of each plan's change in net pension liability not accounted for as deferred inflows/outflows. As a result of implementing GASB 68, the City is reporting a net pension liability and deferred inflows/outflows of resources related to pension on the accrual basis of accounting.

Net position may serve over time as useful indicator of a government's financial position. The City's total assets and deferred outflows of resources exceeded its total liabilities and deferred inflows of resources at the close of 2017 by \$72,037,766. Due to the implementation of GASB 68 and the addition of the City's net pension liability of \$26,569,333, the City's unrestricted net position was a negative \$9,941,237.

The largest portion of the City's total net position (98.95 percent) reflects its net investment in capital assets, i.e. land, buildings, machinery, equipment, vehicles and infrastructure, less any related outstanding debt used to acquire those assets along with related deferred outflows/inflows of resources. The City uses these capital assets to provide services to citizens; consequently, these assets are not available for future spending. Although the City's investment in its capital assets is reported net of related debt and related deferred outflows/inflows of resources, it should be noted that resources needed to repay this debt must be provided from other sources since the capital assets themselves cannot be used to liquidate those liabilities and related deferred inflows of resources.

Total assets increased by \$9,991,273 during the current year. The following factors were responsible for the change in total assets:

- Investment in the infrastructure of the City continued in 2017
- The City started multiple new reconstruction projects, including reconstruction of Snow Rd., Bowfin Blvd., Calvin Dr., Middlebrook Blvd. and Syliva Dr.
- Capital equipment and multiple vehicles were purchased or encumbered to be purchased in 2017.
 1. 8 – Police Vehicles (\$269,014)
 2. Rescue Squad (\$286,493)
 3. 2 - Salt Trucks (\$286,098)
 4. 2- Fire Vehicles (\$127,691)
 5. Sewer Vactor (\$344,157)
 6. 2 – Rubbish Packers (\$592,000)

Total liabilities increased by \$9,276,550, which is primarily due to the issuance of Energy Conservation Bond for the Community Center Renovation Project and the inception of multiple capital leases.

City of Brook Park, Ohio

Management's Discussion and Analysis (Unaudited) (continued)

For the Year Ended December 31, 2017

Table 2 shows the changes in net position for 2017 as compared with 2016.

Table 2
Changes in Net Position

	<u>2017</u>	<u>2016</u>
REVENUES		
Program Revenues:		
Charges for services	\$ 3,860,556	\$ 3,613,822
Operating grants and contributions	929,995	1,287,512
Capital grants and contributions	2,751,058	585,456
Total Program Revenues	<u>7,541,609</u>	<u>5,486,790</u>
General Revenues:		
Property taxes	1,852,018	1,836,353
Municipal income and other taxes	19,774,881	19,608,280
Grants and entitlements	600,624	618,590
Investment income	112,037	62,985
All other revenues	24,845	16,088
Total General Revenues	<u>22,364,405</u>	<u>22,142,296</u>
Total Revenues	<u>29,906,014</u>	<u>27,629,086</u>
EXPENSES		
Program Expenses:		
Security of persons and property	12,555,307	12,063,794
General government	4,432,813	4,756,377
Public works	4,130,367	3,228,252
Leisure time activities	1,752,451	1,567,408
Transportation	3,610,372	2,946,070
Community development	1,371,587	1,637,055
Public health and welfare	247,059	209,629
Interest and fiscal charges	512,537	238,212
Total Expenses	<u>28,612,493</u>	<u>26,646,797</u>
Change in Net Position	1,293,521	982,289
Net Position - Beginning of Year	<u>70,744,245</u>	<u>69,761,956</u>
Net Position - End of Year	<u>\$ 72,037,766</u>	<u>\$ 70,744,245</u>

Governmental Activities

Several revenue sources fund the City's governmental activities, with City income tax being the largest contributor. The City's income tax rate is two percent on gross income and has not changed since 1991. Residents of the City who work in other communities and pay the withholding tax to those municipalities receive a 100 percent tax credit of up to two percent on their City income tax. During 2017, the revenues generated from municipal income tax and other miscellaneous taxes amounted to \$19,774,881. The 0.85 percent increase in income tax collections from 2016 to 2017 can mostly be attributed to withholding and net profit tax collections.

City of Brook Park, Ohio

Management's Discussion and Analysis (Unaudited) (continued)

For the Year Ended December 31, 2017

In 2017, capital grants and contribution increased by \$2,165,602 and this was attributed to the reconstruction project of Snow Road.

For 2017, City income tax revenue of 20 percent is earmarked for specific capital improvements. These revenues are allocated by City ordinance, providing that a substantial portion of the City's income tax collections be set aside for roads, city facilities and other capital requirements.

Of the \$29,906,014 in total revenue, municipal income tax and other taxes accounted for 66.12 percent, property taxes accounted for 6.19 percent, charges for services accounted for 12.91 percent, and capital grants and contributions accounted for 9.20 percent of total revenue.

The combination of municipal income tax, property tax, charges for services, intergovernmental funding and operating and capital grants and contributions were sufficient to fund all of the expenses in the governmental activities. The City monitors its sources of revenues very closely for fluctuations. For the most part, slight increases in total functional expenses are a direct result of the City's conscious effort to control costs in a declining economic environment. The largest program functions for the City relate to security of persons and property and general government. During 2017, security of persons and property accounted for 43.88 percent of program expenses, and 15.49 percent of program expenses related to general government. In 2017, the overall increase in expenses was \$1,965,676 or 7.38 percent. This increase in expenses was mainly due to increases in security of persons and property, public works, and transportation.

Currently there are 36 full-time sworn officers in the police department. The department wrote 6,258 tickets in 2017, which constituted a 6.32 percent increase over tickets written in 2017.

The fire department consists of 30 full-time firefighters. The department handled 3,477 calls for assistance in 2017, of which approximately 2,901 were for emergency medical services (EMS), with the balance attributed to fire and fire-related incidents. Total calls for assistance represented an increase of nearly 12.92 percent over 2016.

Program Expenses

For the year ended December 31, 2017, the City's total cost of services was \$28,612,493, with a net cost of services totaling \$21,070,864.

Table 3 itemizes fiscal year 2017 program expenses by specific function.

Table 3
Program Expenses

	Total Cost of Services 2017	Net Cost of Services 2017
Security of persons and property	\$ 12,555,307	\$ 11,323,813
General government	4,432,813	3,504,673
Public works	4,130,367	3,822,061
Transportation	3,610,372	288,993
Leisure time activities	1,752,451	1,435,789
Community development	1,371,587	(63,911)
Public health and welfare	247,059	246,929
Interest and fiscal charges	512,537	512,537
Total cost of service	<u>\$ 28,612,493</u>	<u>\$ 21,070,884</u>

City of Brook Park, Ohio

Management's Discussion and Analysis (Unaudited) (continued)

For the Year Ended December 31, 2017

The table on the previous page shows the total cost of services as well as the net cost of services. That is, it identifies the cost of the services supported by tax revenue and unrestricted intergovernmental revenues.

As referenced, most of the City's governmental activities rely on general revenues (property taxes, municipal income tax, grants, etc.) to support program expenses.

The City's Funds

Governmental Funds

The focus of the City's governmental funds is to provide information on near-term inflows, outflows and balances of spendable resources. Such information is useful in assessing the City's financing requirements. In particular, unassigned fund balances may serve as a useful measure of a government's net resources available for spending at the end of the year. Information about the City's governmental funds begins on page 19.

As of the end of the current fiscal year, the City's governmental funds reported combined ending fund balances of \$19,785,690. Of that amount, \$6,028,519 constitutes unassigned fund balances that are available for spending at the government's discretion without externally or internally imposed constraints. The remaining balance is nonspendable, restricted, committed, or assigned to indicate that it is not available for new spending.

General Fund

The General Fund is the chief operating fund of the City. As of December 31, 2017, the total fund balance for the General Fund was \$8,920,518, of which \$6,028,519 was unassigned. As a measure of the General Fund's liquidity, it may be useful to compare both unassigned fund balance and total fund balance to fund expenditures (not including other financing uses). Unassigned fund balance represents 31.91 percent of total General Fund expenditures, while total fund balance represents 47.24 percent of that same amount.

During 2017, the said fund balance decreased by \$828,479 or 8.50 percent. This decrease is due to the City's transfers out to the Capital Improvement Fund.

Capital Improvements Fund

The Capital Improvements Fund accounts for intergovernmental revenue in the form of grants as well as the portion of municipal income tax allocated by City Council for the purpose of improving, constructing, maintaining and purchasing those items necessary to enhance the operation of the City. As of December 31, 2017, the total fund balance for the Capital Improvements Fund was \$6,352,189, of which \$3,691,352 was committed due to constraints imposed by Council and \$2,660,837 was restricted by external constraints. The said fund balance increased by \$2,897,630 during 2017. This increase is mainly due to the issuance of bonds for the improvements to the Community Center and inception of new capital leases.

City of Brook Park, Ohio

Management's Discussion and Analysis (Unaudited) (continued)

For the Year Ended December 31, 2017

City Budget

The City's budget is prepared according to Ohio law and accounts for certain transactions on a basis of cash receipts, cash disbursements and encumbrances. The most significant budgeted fund is the General Fund. Except for agency funds, an annual appropriation budget is legally required to be prepared for all funds of the City. City Council is provided with a detailed line item budget for all departments. After discussions at regularly held council meetings that are open to the public, the budget is adopted at the department level by object. Within each object, appropriations can be transferred between line items with the approval of the Finance Director and the respective department head. Council must approve any revisions in the budget that alter object level totals or total appropriations for any department or fund. During the course of 2017, the City amended its General Fund budget twice. The finance department watches all department expenditures closely to monitor compliance with allocated budgets and provides monthly reports to City Council that depicts monthly and year-to-date activity.

For the General Fund, the final budget basis revenue plus other financing sources was \$23,068,955 as compared to the original budget estimate plus other financing sources of \$22,610,043. The final budget was higher than the original budget due to higher than expected income tax collections and fines and forfeitures. The final appropriations plus other financing uses of \$25,723,854 were sufficient to meet the actual expenditures plus other financing uses for the year, \$23,726,945.

Capital Assets and Debt Administration

Capital Assets

As of December 31, 2017, the City had \$86,214,109 invested in land, construction in progress, buildings and improvements, improvements other than buildings, machinery and equipment, furniture and fixtures, vehicles and infrastructure. Table 4 shows fiscal year 2017 balances of capital assets, net of depreciation, as compared to 2016.

Table 4
Capital Assets at Year End
(Net of Depreciation)

	<u>2017</u>	<u>2016</u>
Land	\$ 4,926,923	\$ 4,896,683
Construction in progress	13,381,514	4,366,746
Buildings and improvements	7,792,683	8,127,164
Improvements other than buildings	759,286	865,787
Machinery and equipment	1,231,138	1,411,889
Furniture and fixtures	18,289	23,331
Vehicles	3,751,308	2,400,147
Infrastructure:		
Streets	36,559,843	37,613,145
Sewers	16,732,052	17,263,580
Water Lines	1,061,073	722,371
Total Capital Assets	<u>\$ 86,214,109</u>	<u>\$ 77,690,843</u>

City of Brook Park, Ohio

Management's Discussion and Analysis (Unaudited) (continued)

For the Year Ended December 31, 2017

In 2017, as previously referenced, numerous construction projects, i.e. major road repairs and significant capital improvements to the Community Center, commenced and new vehicles were purchased, resulting in increases to construction in progress and vehicles.

With respect to infrastructure, the City engineer maintains a comprehensive listing of all the streets, bridges, culverts and sewer lines located within the City. As part of the annual road maintenance program, the City engineer evaluates the condition of each street after each winter and prepares a list of streets to be either resurfaced or crack sealed. In the case of concrete roads, the damaged portion will be either replaced or repaired. After approval from City Council, the projects are bid to get the best possible pricing from contractors. For additional information on capital assets, see Note 7 of the basic financial statements.

Debt

On December 31, 2017, the City had \$15,693,829 in outstanding debt, with \$1,469,126 of that debt due within one year.

Table 5 summarizes general obligation bonds, capital leases, and OPWC loans.

Table 5
Outstanding Debt at Year End

	<u>2017</u>	<u>2016</u>
General obligation bonds	\$ 11,340,263	\$ 6,654,127
Capital leases	1,720,425	449,965
OPWC loans	2,633,141	2,788,901
Total outstanding debt	<u>\$ 15,693,829</u>	<u>\$ 9,892,993</u>

As of December 31, 2017, the City's overall legal debt margin was \$31,841,983, with an unvoted debt margin of \$11,289,837.

More detailed information about the City's debt liabilities is presented in Note 8 of the basic financial statements.

Current Financial Related Activities

Local officials and Ford executives will continue to meet frequently to discuss current operating conditions and to strategize for new business alternatives that will keep the Brook Park Ford facility competitive in their corporate structure, resulting in a long-term existence within the City. In addition, discussions will continue on how to best develop the vacant acreage on the campus.

NASA Glenn, the largest taxpayer in the City, continues to be a tremendous asset to the community and region. City officials will continue to meet with Glenn administrators to discuss the current and future state of their facility.

In closing, local officials continue to work through the economic challenges facing the City and remain committed to providing full disclosure of the City's financial position to its residents.

City of Brook Park, Ohio

Management's Discussion and Analysis (Unaudited) (continued)

For the Year Ended December 31, 2017

Contacting the City's Finance Department

The CAFR is designed to provide our citizens, taxpayers, investors and creditors with a general overview of the City's finances and to show the City's accountability for the money it receives. If you have any questions about this CAFR or need additional financial information, please contact Finance Director Gregory M. Cingle, at the City of Brook Park, 6161 Engle Rd., Brook Park, Ohio, (216) 433-1300, or e-mail to info@cityofbrookpark.com.

City of Brook Park, Ohio
Statement of Net Position
December 31, 2017

	Governmental Activities
ASSETS	
Equity in Pooled Cash and Cash Equivalents	\$ 21,327,854
Cash and Cash Equivalents:	
With Escrow Agents	439,455
Materials and Supplies Inventory	87,820
Accounts Receivable	172,212
Accrued Interest Receivable	11,026
Intergovernmental Receivable	1,546,247
Prepaid Items	148,690
Municipal Income Taxes Receivable	3,097,354
Property Taxes Receivable	1,754,380
Special Assessments Receivable	60,777
Net Pension Asset	11,569
Nondepreciable Capital Assets	18,308,437
Depreciable Capital Assets	67,905,672
Total Assets	<u>114,871,493</u>
DEFERRED OUTFLOWS OF RESOURCES	
Pension	6,841,698
Total Deferred Outflows of Resources	<u>6,841,698</u>
LIABILITIES	
Accounts Payable	150,909
Contracts Payable	1,224,584
Accrued Wages and Benefits	347,387
Intergovernmental Payable	8,750
Post-Employment Obligation Payable	55,490
Matured Compensated Absences Payable	32,945
Accrued Interest Payable	48,672
Retainage Payable	359,008
Long-term Liabilities:	
Due within one year	1,784,311
Due in more than one year:	
Net Pension Liability	26,569,333
Other amounts due in more than one year	16,038,965
Total Liabilities	<u>46,620,354</u>
DEFERRED INFLOWS OF RESOURCES	
Property Taxes	1,677,004
Pension	1,378,067
Total Deferred Inflows of Resources	<u>3,055,071</u>
NET POSITION	
Net Investment in Capital Assets	71,280,520
Restricted for:	
Debt Services	1,162,932
Capital Projects	6,592,223
Economic Development	250,866
Street Paving and Repair	1,552,700
Recreation	452,474
Public Safety	388,716
Other Purposes	298,572
Unrestricted	(9,941,237)
Total Net Position	<u>\$ 72,037,766</u>

The notes to the basic financial statements are an integral part of this statement

City of Brook Park, Ohio
Statement of Activities
For the Year Ended December 31, 2017

	<u>Expenses</u>	<u>Program Revenues</u>		<u>Capital Grants and Contributions</u>	<u>Net (Expense) Revenue and Changes in Net Position</u>
		<u>Charges for Services</u>	<u>Operating Grants and Contributions</u>		
Governmental activities:					
Security of Persons and Property					
Police and Others	\$ 7,434,664	\$ 649,061	\$ 33,690	\$ -	\$ (6,751,913)
Fire	5,120,643	548,743	-	-	(4,571,900)
Public Health and Welfare	247,059	130	-	-	(246,929)
Leisure Time Activities	1,752,451	311,662	5,000	-	(1,435,789)
Community Development	1,371,587	1,435,498	-	-	63,911
Public Works	4,130,367	16,462	-	291,844	(3,822,061)
Transportation	3,610,372	1,000	891,305	2,429,074	(288,993)
General Government	4,432,813	898,000	-	30,140	(3,504,673)
Interest and Fiscal Charges	512,537	-	-	-	(512,537)
Total Governmental activities	\$ 28,612,493	\$ 3,860,556	\$ 929,995	\$ 2,751,058	(21,070,884)

General Revenues:

Property Taxes levied for:

General Purposes	1,534,626
Other Purposes	317,392

Municipal Income and Other Taxes levied for:

General Purposes	16,900,883
Capital Outlay	2,873,998

Grants & Entitlements not restricted to specific programs 600,624

Investment Income 112,037

All Other Revenues 24,845

Total General Revenues 22,364,405

Change in Net Position 1,293,521

Net Position - Beginning of Year 70,744,245

Net Position - End of Year \$ 72,037,766

The notes to the basic financial statements are an integral part of this statement

City of Brook Park, Ohio
Balance Sheet – Governmental Funds
December 31, 2017

	<u>General Fund</u>	<u>Capital Improvements Fund</u>	<u>Other Governmental Funds</u>	<u>Total Governmental Funds</u>
ASSETS				
Equity in Pooled Cash and Cash Equivalents	\$ 7,399,592	\$ 7,117,569	\$ 3,742,733	\$ 18,259,894
Cash and Cash Equivalents:				
With Escrow Agents	-	439,455	-	439,455
Materials and Supplies Inventory	87,820	-	-	87,820
Accrued Interest Receivable	8,324	-	2,702	11,026
Accounts Receivable	170,212	-	2,000	172,212
Intergovernmental Receivable	282,881	31,949	1,231,417	1,546,247
Prepaid Items	148,298	-	392	148,690
Municipal Income Taxes Receivable	2,507,488	589,866	-	3,097,354
Property Taxes Receivable	1,432,483	-	321,897	1,754,380
Special Assessments Receivable	-	550	60,227	60,777
Total Assets	<u>12,037,098</u>	<u>8,179,389</u>	<u>5,361,368</u>	<u>25,577,855</u>
LIABILITIES, DEFERRED INFLOWS OF RESOURCES AND FUND BALANCES				
Accounts Payable	\$ 125,891	\$ 25,018	\$ -	\$ 150,909
Accrued Wages and Benefits	230,614	-	116,773	347,387
Contracts Payable	-	1,223,558	1,026	1,224,584
Intergovernmental Payable	8,438	-	312	8,750
Matured Compensated Absences Payable	32,945	-	-	32,945
Retainage Payable	-	322,613	36,395	359,008
Total Liabilities	<u>397,888</u>	<u>1,571,189</u>	<u>154,506</u>	<u>2,123,583</u>
Deferred Inflows of Resources:				
Property Taxes	1,369,337	-	307,667	1,677,004
Unavailable Revenue - Delinquent Property Taxes	63,146	-	14,230	77,376
Unavailable Revenue - Income Taxes	1,021,846	255,461	-	1,277,307
Unavailable Revenue - Other	264,363	550	371,982	636,895
Total Deferred Inflows of Resources	<u>2,718,692</u>	<u>256,011</u>	<u>693,879</u>	<u>3,668,582</u>
Fund Balances:				
Nonspendable	236,118	-	392	236,510
Restricted	-	2,660,837	2,646,367	5,307,204
Committed	2,251,239	3,691,352	761,175	6,703,766
Assigned	404,642	-	1,105,049	1,509,691
Unassigned (Deficit)	6,028,519	-	-	6,028,519
Total Fund Balances	<u>8,920,518</u>	<u>6,352,189</u>	<u>4,512,983</u>	<u>19,785,690</u>
Total Liabilities, Deferred Inflows of Resources and Fund Balances	<u>\$ 12,037,098</u>	<u>\$ 8,179,389</u>	<u>\$ 5,361,368</u>	<u>\$ 25,577,855</u>

The notes to the basic financial statements are an integral part of this statement

City of Brook Park, Ohio

Reconciliation of Total Governmental Funds Balances to Net Position of Governmental Activities December 31, 2017

Total Governmental Funds Balance \$ 19,785,690

Amounts reported for Governmental Activities in the Statement of Net Position are different because:

Capital Assets used in Governmental Activities are not financial resources and, therefore, are not reported in the funds 86,214,109

Other long-term assets are not available to pay for current-period expenditures and, therefore, are unavailable revenues in the funds:

Delinquent property taxes	\$ 77,376	
Municipal income and other taxes	1,277,307	
Special assessments	60,777	
Intergovernmental	530,403	
Charges for services	45,715	
Total		1,991,578

The post-employment obligation is a result of the annual OPEB costs exceeding the OPEB expenses. (55,490)

In the Statement of Activities, interest is accrued on outstanding bonds, whereas in Governmental funds, an interest expenditure is reported when due. (48,672)

Internal Service funds are used by management to charge the costs of certain activities, such as insurance to individual funds. The assets of the Internal Service funds are included in Governmental Activities in the Statement of Net Position. 3,067,960

The net pension liability/asset is not due and payable in the current period; therefore, the liability/asset and related deferred inflows/outflows are not reported in governmental funds:

Deferred Outflows - Pension	6,841,698	
Deferred Inflows - Pension	(1,378,067)	
Net Pension Liability/Asset	(26,557,764)	
Total		(21,094,133)

Long-term liabilities, including bonds payable, are not due and payable in the current period and therefore are not reported in the funds:

General obligation bonds	(10,920,000)	
OPWC loans	(2,633,141)	
Unamortized bond premiums	(420,263)	
Capital leases	(1,720,425)	
Accrued compensated absences	(2,129,447)	
Total		(17,823,276)

Net Position of Governmental Activities \$ 72,037,766

The notes to the basic financial statements are an integral part of this statement

City of Brook Park, Ohio

Statement of Revenues, Expenditures and Changes in Fund Balances Governmental Funds For the Year Ended December 31, 2017

	<u>General Fund</u>	<u>Capital Improvements Fund</u>	<u>Other Governmental Funds</u>	<u>Total Governmental Funds</u>
REVENUES				
Property Taxes	\$ 1,536,865	\$ -	\$ 317,913	\$ 1,854,778
Municipal Income Taxes	16,571,027	2,865,258	-	19,436,285
Other Taxes	294,893	-	-	294,893
Intergovernmental	582,833	2,688,490	972,611	4,243,934
Interest	92,788	90	19,159	112,037
Licenses and Permits	595,947	-	46,135	642,082
Fines and Forfeitures	700,727	-	6,450	707,177
Rentals	53,299	-	-	53,299
Charges for Services	1,637,373	16,462	109,878	1,763,713
Contributions and Donations	1,825	-	-	1,825
Special Assessments	-	-	60,216	60,216
All Other Revenues	560,492	500	85,477	646,469
Total Revenues	<u>22,628,069</u>	<u>5,570,800</u>	<u>1,617,839</u>	<u>29,816,708</u>
EXPENDITURES				
Security of Persons and Property:				
Police and Others	5,924,369	-	733,365	6,657,734
Fire	3,748,306	-	643,642	4,391,948
Public Health and Welfare	111,114	-	123,674	234,788
Leisure Time Activities	1,205,228	-	61,041	1,266,269
Community Development	689,548	58,611	469,896	1,218,055
Public Works	2,391,617	-	-	2,391,617
Transportation	1,182,582	-	720,677	1,903,259
General Government	3,629,784	117,381	596	3,747,761
Capital Outlay	-	11,275,405	1,431,866	12,707,271
Debt Service:				
Principal Retirement	-	726,863	645,760	1,372,623
Interest and Fiscal Charges	-	8,165	342,249	350,414
Bond Issuance Costs	-	-	160,098	160,098
Total Expenditures	<u>18,882,548</u>	<u>12,186,425</u>	<u>5,332,864</u>	<u>36,401,837</u>
Excess of Revenues (Under) Expenditures	<u>3,745,521</u>	<u>(6,615,625)</u>	<u>(3,715,025)</u>	<u>(6,585,129)</u>
OTHER FINANCING SOURCES (USES)				
Inception of Capital Lease	-	1,997,323	-	1,997,323
General Obligation Bonds Issued	-	4,980,000	-	4,980,000
Premium on Debt Issuance	-	-	219,628	219,628
Transfers In	-	3,189,000	2,038,068	5,227,068
Transfers Out	(4,574,000)	(653,068)	-	(5,227,068)
Total Other Financing Sources (Uses)	<u>(4,574,000)</u>	<u>9,513,255</u>	<u>2,257,696</u>	<u>7,196,951</u>
Net Change in Fund Balances	(828,479)	2,897,630	(1,457,329)	611,822
Fund Balances - Beginning of Year	9,748,997	3,454,559	5,970,312	19,173,868
Fund Balances - End of Year	<u>\$ 8,920,518</u>	<u>\$ 6,352,189</u>	<u>\$ 4,512,983</u>	<u>\$ 19,785,690</u>

The notes to the basic financial statements are an integral part of this statement

City of Brook Park, Ohio

Reconciliation of the Statement of Revenues, Expenditures and Changes in Fund Balances of Governmental Funds to the Statement of Activities For the Year Ended December 31, 2017

Net Change in Fund Balances-Total Governmental Funds \$ 611,822

Amounts reported for Governmental Activities in the Statement of Activities are different because:

Governmental funds report capital outlays as expenditures. However, in the Statement of Activities, the cost of those assets is allocated over their estimated useful lives as depreciation expense. This is the amount by which capital outlays exceeded depreciation in the current period.

Capital Outlay	\$ 9,810,015	
Capital Contributions	2,427,265	
Depreciation	<u>(3,435,193)</u>	
Total		8,802,087

In the Statement of Activities, only the loss on the disposal of capital assets is reported, whereas, in the Governmental Funds, the proceeds from the disposals increase financial resources. Thus, the change in net position differs from the change in fund balance by the net book value of the capital assets. (278,821)

Revenues in the Statement of Activities that do not provide current financial resources are not reported as revenues in the funds.

Delinquent property taxes	(2,760)	
Municipal income and other taxes	43,703	
Special assessments	(24,949)	
Intergovernmental	2,364	
Charges for services	<u>40,808</u>	
Total		59,166

Repayment of bond, lease, and loan principal are expenditures in the Governmental funds, but the repayment reduces long-term liabilities in the Statement of Net Position. 1,372,623

Contractually required contributions are reported as expenditures in governmental funds; however, the statement of net position reports these amounts as deferred outflows 2,030,359

Except for amounts reported as deferred inflows/outflows, changes in the net pension liability are reported as pension expense in the statement of activities. (3,693,694)

The issuance of long-term debt provides current financial resources to governmental funds, but has no effect on net position

General obligation Bonds issued	(4,980,000)	
Inception of Capital Leases	(1,997,323)	
Premiums on Bonds Issued	<u>(219,628)</u>	
		(7,196,951)

Some expenses reported in the Statement of Activities do not require the use of current financial resources and therefore are not reported as expenditures in Governmental funds.

Accrued compensated absences	(161,568)	
Accrued interest on bonds	(25,517)	
Annual OPEB cost	(162,119)	
Amortization of bond premiums	<u>23,492</u>	
Total		(325,712)

Internal Service funds are used by management to charge costs to certain activities, such as insurance to individual funds. The net revenue (expense) of Internal Service funds are reported in the Governmental Activities. (87,358)

Change in Net Position of Governmental Activities \$ 1,293,521

The notes to the basic financial statements are an integral part of this statement

City of Brook Park, Ohio

Statement of Revenues, Expenditures and Changes in Fund Balances – Budget (Non-GAAP Budgetary Basis) and Actual

General Fund

For the Year Ended December 31, 2017

	Budgeted Amounts		Actual	Variance with
	Original	Final		Final Budget Positive (Negative)
Revenues:				
Property Taxes	\$ 1,542,871	\$ 1,536,865	\$ 1,536,865	\$ -
Municipal Income Taxes	16,268,600	16,582,000	16,558,288	(23,712)
Other Taxes	347,600	318,609	318,609	-
Intergovernmental	697,549	589,346	589,346	-
Interest	65,000	89,466	89,466	-
Licenses and Permits	742,060	650,839	643,068	(7,771)
Fines and Forfeitures	676,000	687,110	698,735	11,625
Rentals	53,299	53,299	53,299	-
Charges for Services	1,594,858	1,606,744	1,645,683	38,939
Contributions and Donations	1,825	1,825	1,825	-
All Other Revenues	273,381	605,852	563,059	(42,793)
Total Revenues	22,263,043	22,721,955	22,698,243	(23,712)
Expenditures:				
Current:				
Security of Persons and Property	9,700,119	9,903,051	9,710,848	192,203
Public Health and Welfare	116,186	112,196	111,108	1,088
Leisure Time Activities	1,321,551	1,317,051	1,193,976	123,075
Community Development	837,006	851,622	826,201	25,421
Public Works	2,257,649	2,357,078	2,262,779	94,299
Transportation	532,308	534,963	451,742	83,221
General Government	5,350,341	5,605,893	4,496,291	1,109,602
Total Expenditures	20,115,160	20,681,854	19,052,945	1,628,909
Excess of Revenues Over (Under) Expenditures	2,147,883	2,040,101	3,645,298	1,605,197
Other Financing Sources (Uses)				
Transfer In	347,000	347,000	-	(347,000)
Transfers Out	(4,677,000)	(5,042,000)	(4,674,000)	368,000
Total Other Financing Sources (Uses)	(4,330,000)	(4,695,000)	(4,674,000)	21,000
Net Change in Fund Balance	(2,182,117)	(2,654,899)	(1,028,702)	1,626,197
Cash Fund Balance - Beginning of Year	8,129,717	8,129,717	8,129,717	-
Current Year Encumbrances	-	-	270,439	270,439
Cash Fund Balance - End of Year	\$ 5,947,600	\$ 5,474,818	\$ 7,371,454	\$ 1,896,636

The notes to the basic financial statements are an integral part of this statement

City of Brook Park, Ohio
 Statement of Net Position
 Proprietary Fund
 December 31, 2017

	<u>Governmental Activities</u> <u>Internal Service Fund</u>
ASSETS	
Current Assets:	
Equity in Pooled Cash and Cash Equivalents	<u>\$ 3,067,960</u>
Total Assets	<u>3,067,960</u>
 NET POSITION	
Unrestricted	<u>3,067,960</u>
Total Net Position	<u>\$ 3,067,960</u>

The notes to the basic financial statements are an integral part of this statement

City of Brook Park, Ohio

Statement of Revenues, Expenses and Changes in Net Position

Proprietary Fund

For The Year Ended December 31, 2017

	Governmental Activities
	Internal Service Fund
OPERATING REVENUES	
Charges for Services	\$ 7,551
Total Operating Revenues	<u>7,551</u>
OPERATING EXPENSES	
Fringe Benefits	94,278
Contractual Services	631
Total Operating Expense	<u>94,909</u>
Change in Net Position	(87,358)
Net Position - Beginning of Year	<u>3,155,318</u>
Net Position- End of Year	<u><u>\$ 3,067,960</u></u>

The notes to the basic financial statements are an integral part of this statement

City of Brook Park, Ohio
Statement of Cash Flows
Proprietary Fund
For The Year Ended December 31, 2017

	Governmental Activities
	Internal Service Fund
CASH FLOWS FROM OPERATING ACTIVITIES	
Cash Received from Charges for Services	\$ 1,792,710
Cash Payments for Goods and Services	(631)
Cash Payments for Claims	(1,911,810)
Net Cash Provided by Operating Activities	<u>(119,731)</u>
 Net Increase in Cash and Cash Equivalents	 (119,731)
 Cash and Cash Equivalents - Beginning of Year	 <u>3,187,691</u>
Cash and Cash Equivalents - End of Year	<u>\$ 3,067,960</u>
 RECONCILIATION OF OPERATING INCOME TO NET CASH PROVIDED BY OPERATING ACTIVITIES	
Operating Income	\$ (87,358)
Adjustments:	
(Increase) in Assets:	
Accounts Receivable	41,894
Prepaid Items	24,748
(Decrease) in Liabilities:	
Claims Payable	(99,015)
Net Cash Provided by Operating Activities	<u>\$ (119,731)</u>

The notes to the basic financial statements are an integral part of this statement

City of Brook Park, Ohio
Statement of Fiduciary Net Position
Fiduciary Fund
December 31, 2017

	Agency Funds
Assets	
Equity in Pooled Cash and Cash Equivalents	\$ 106,268
Cash and Cash Equivalents:	
in Segregated Accounts	<u>45,388</u>
Total Assets	<u><u>\$ 151,656</u></u>
Liabilities	
Deposits Held and Due to Others	<u><u>\$ 151,656</u></u>

The notes to the basic financial statements are an integral part of this statement

Notes to Basic Financial Statements

City of Brook Park, Ohio

Notes to the Basic Financial Statements

For The Year Ended December 31, 2017

Note 1: The Reporting Entity

The City of Brook Park (the City) is a home rule municipal corporation established under the laws of the State of Ohio which operates under its own Charter. The current Charter, which provides for a mayor-council form of government, was adopted October 18, 1966.

A reporting entity is comprised of the primary government, component units and other organizations that are included to ensure that the financial statements are not misleading. The primary government of the City consists of all funds, departments, boards and agencies that are not legally separate from the City. For the City, this includes police and fire protection, parks and recreation, planning, zoning, street maintenance and repair, refuse collection and general administrative services. The City's departments include a public safety department, a public service department, a street maintenance department, a sanitation system, a parks and recreation department, a planning and zoning department, and a staff to provide support (i.e., payroll processing, accounts payable, and revenue collection) to the service providers. The operation of each of these activities and entities is directly controlled by the City Council through the budgetary process.

The Mayor's Court (the Court), which provides judicial services, is responsible for the levying and collecting of fines and forfeitures under state and local laws, and their subsequent distribution to various government agencies. The City budgets and appropriates funds for the operation of the Court and is ultimately responsible for any operating deficits sustained by the Court. The City's share of the fines collected by the Court, along with its share of the Court's administrative and operating costs, is recorded in the City's General Fund. Due to this relationship, the Court is not considered a component unit of the City but rather as part of the primary government unit itself. Monies held by the Court in a fiduciary capacity are recorded as an agency fund in the accompanying financial statements.

Component units are legally separate organizations for which the City is financially accountable. The City is financially accountable for an organization if the City appoints a voting majority of the organization's governing board and (1) the City is able to significantly influence the programs or services performed or provided by the organization; or (2) the City is legally entitled to or can otherwise access the organization's resources; the City is legally obligated or has otherwise assumed the responsibility to finance deficits of, or provide financial support to the organization. Component units may also include organizations that are fiscally dependent on the City in that the City approves the budget, the issuance of debt, or the levying of taxes. The City has no component units.

Jointly Governed Organizations

Southwest General Health Center

Southwest General Health Center is an Ohio nonprofit corporation providing health services. The Health Center is a jointly governed organization among the communities of Berea, Brook Park, Columbia Township, Middleburg Heights, Olmsted Falls and Strongsville.

The Health Center is governed by a Board of Trustees consisting of the following: one member of the legislative body from each of the political subdivisions, one resident from each of the political subdivisions who is not a member of the legislative body, three persons who are residents of any of the participating political subdivisions, the president and the executive vice president of the corporations, and the president and the vice president of the medical staff. The legislative body of each political subdivision elects their own member to serve on the Board of Trustees of the Health Center.

City of Brook Park, Ohio

Notes to the Basic Financial Statements (continued)

For The Year Ended December 31, 2017

Note 1: The Reporting Entity (continued)

Jointly Governed Organizations (continued)

The Board exercises total control over the operations of the Health Center including budgeting, appropriating, contracting and designating management. Each City's control is limited to its representation on the Board. In 2017, the City of Brook Park contributed \$110,821 of property tax levies and intergovernmental revenue to the Health Center.

Southwest Regional Communications Network Council of Governments

The Southwest Regional Communications Network Council of Governments is a jointly-governed organization between the City and seven other communities. Formed as a Regional Council of Governments as permitted under Ohio Revised Code Section 167.01, the intent of this organization is to establish, own, operate, maintain, and administer, a regional communications network for public safety and public service purposes for the mutual benefit of the participating communities. This organization is controlled by a governing body consisting of each participating community's mayor or his/her delegate or representative. The degree of control exercised by any member is limited to its representation on the governing board. All members agree to contribute the sums of money on a shared basis as agreed per the requirements set forth in the Articles of Understanding. In accordance with GASB Statement No. 14 as amended by GASB Statement No. 61, the City does not have an equity interest in the organization. Financial information may be obtained by writing to the Network Council, at 17401 Holland Road, Brook Park, Ohio 44142.

Note 2: Summary of Significant Accounting Policies

The financial statements of the City have been prepared in conformity with generally accepted accounting principles (GAAP) as applied to local governmental units. The Governmental Accounting Standards Board (GASB) is the accepted standard-setting body for establishing governmental accounting and financial principles. The most significant of the City's accounting policies are described below.

A. Basis of Presentation

The City's basic financial statements consist of government-wide statements, including a statement of net position and a statement of activities, and fund financial statements which provide a more detailed level of financial information.

Government-Wide Financial Statements

The statement of net position and the statement of activities display information about the City as a whole. These statements include the financial activities of the primary government, except for fiduciary funds. The activity of the internal service fund is eliminated to avoid doubling up revenues and expenses.

City of Brook Park, Ohio

Notes to the Basic Financial Statements (continued)

For The Year Ended December 31, 2017

Note 2: Summary of Significant Accounting Policies (continued)

A. Basis of Presentation (continued)

The statement of net position presents the financial condition of the governmental activities of the City at year-end. The statement of activities presents a comparison between direct expenses and program revenues for each program or function of the City's governmental activities. Direct expenses are those that are specifically associated with a service, program or department and therefore clearly identifiable to a particular function. Program revenues include charges paid by the recipient of the goods or services offered by the program, grants and contributions that are restricted to meeting the operational or capital requirements of a particular program and interest earned on grants that is required to be used to support a particular program. Revenues not classified as program revenues are presented as general revenues of the City, with certain limited exceptions. The comparison of direct expenses with program revenues identifies the extent to which each governmental function is self-financing or draws from the general revenues of the City.

Fund Financial Statements

During the year, the City segregates transactions related to certain City functions or activities in separate funds in order to aid financial management and to demonstrate legal compliance. Fund financial statements are designed to present financial information of the City at this more detailed level. The focus of governmental fund financial statements is on major funds. Each major fund is presented in a separate column. Non-Major funds are aggregated and presented in a single column. The internal service fund is presented in a single column on the face of the proprietary fund statements. Fiduciary funds are reported by type.

B. Fund Accounting

The City uses funds to maintain its financial records during the year. A fund is defined as a fiscal and accounting entity with a self-balancing set of accounts. There are three categories of funds: governmental, proprietary and fiduciary.

Governmental Funds

Governmental funds are those through which most governmental functions typically are financed. Governmental fund reporting focuses on the sources, uses and balances of current financial resources. Expendable assets are assigned to the various governmental funds according to the purposes for which they may or must be used. Current liabilities are assigned to the fund from which they will be paid. The difference between governmental fund assets and deferred outflows of resources compared to liabilities and deferred inflows of resources is reported as fund balance. The following are the City's major governmental funds:

General Fund

The General Fund accounts for all financial resources except those required to be accounted for in another fund. The General Fund balance is available to the City for any purpose provided it is expended or transferred according to the charter of the City and/or the general laws of Ohio.

City of Brook Park, Ohio

Notes to the Basic Financial Statements (continued)

For The Year Ended December 31, 2017

Note 2: Summary of Significant Accounting Policies (continued)

B. Fund Accounting (continued)

Capital Improvements Fund

The Capital Improvements Fund accounts for intergovernmental revenues, bond proceeds, and the portion of municipal income tax allocated by Council for the purpose of improving, constructing, maintaining, and purchasing those items necessary to enhance the operation of the City.

The other governmental funds of the City account for grants and other resources whose use is restricted, committed, or assigned to a particular purpose.

Proprietary Funds

Proprietary fund reporting focuses on the determination of operating income, changes in net position, financial position and cash flows. Proprietary funds are classified as either enterprise or internal service. The City has no enterprise funds.

Internal Service Fund

Internal service funds account for the financing of services provided by one department or agency to other departments or agencies of the City on a cost-reimbursement basis. The City's internal service fund reports on a self-insurance program for employee medical benefits.

Fiduciary Funds

Fiduciary fund reporting focuses on net position and changes in net position. The fiduciary fund category is split into four classifications: pension trust funds, investment trust funds, private-purpose trust funds and agency funds. Trust funds are used to account for assets held by the City under a trust agreement for individuals, private organizations, or other governments and are therefore not available to support the City's own programs. Agency funds are custodial in nature (assets equal liabilities) and do not involve measurement of results of operations. The City's only fiduciary funds are agency funds. The City's agency funds account for: street opening fees, mayor's court activity, building code fees, employees' share of payroll deductions due to other agencies, assets held for the Southwest Regional Communication jointly governed organization, and employees' share of pension contributions.

C. Measurement Focus

Government-Wide Financial Statements

The government-wide financial statements are prepared using the economic resources measurement focus. All assets and deferred outflows of resources and all liabilities and deferred inflows of resources associated with the operation of the City are included on the Statement of Net Position, except for fiduciary funds. The Statement of Activities presents increases (e.g. revenues) and decreases (e.g. expenses) in total net position.

City of Brook Park, Ohio

Notes to the Basic Financial Statements (continued)

For The Year Ended December 31, 2017

Note 2: Summary of Significant Accounting Policies (continued)

C. Measurement Focus (continued)

Fund Financial Statements

All governmental funds are accounted for using a flow of current financial resources measurement focus. With this measurement focus, only current assets and deferred outflows of resources and current liabilities and deferred inflows of resources generally are included on the balance sheet. The statement of revenues, expenditures and changes in fund balances reports on the sources (i.e., revenues and other financing sources) and uses (i.e., expenditures and other financing uses) of current financial resources. This approach differs from the manner in which the governmental activities of the government-wide financial statements are prepared. Governmental fund financial statements therefore include reconciliations with brief explanations to better identify the relationship between the government-wide statements and the statements for governmental funds.

Like the government-wide statements, all proprietary funds are accounted for on a flow of economic resources measurement focus. All assets and deferred outflows of resources and all liabilities and deferred inflows of resources associated with the operation of these funds are included on the statement of net position. The statement of revenues, expenses and changes in net position presents increases (i.e., revenues) and decreases (i.e., expenses) in total net position. The statement of cash flows provides information about how the City finances and meets the cash flow needs of its proprietary activities.

D. Basis of Accounting

Basis of accounting determines when transactions are recorded in the financial records and reported on the financial statements. Government-wide financial statements are prepared using the accrual basis of accounting; proprietary and fiduciary funds also use the accrual basis of accounting. Governmental funds use the modified accrual basis of accounting. Differences in the accrual and modified accrual basis of accounting arise in the recognition of revenue, the recording of deferred outflows/inflows of resources, and in the presentation of expenses versus expenditures.

Revenues – Exchange and Non-Exchange Transactions

Revenue resulting from exchange transactions, in which each party gives and receives essentially equal value, is recorded on the accrual basis when the exchange takes place. On a modified accrual basis, revenue is recorded in the year in which the resources are measurable and become available. Available means that the resources will be collected within the current year or are expected to be collected soon enough thereafter to be used to pay liabilities of the current year. The available period for the City is sixty days after year-end.

City of Brook Park, Ohio

Notes to the Basic Financial Statements (continued)

For The Year Ended December 31, 2017

Note 2: Summary of Significant Accounting Policies (continued)

D. Basis of Accounting (continued)

Non-exchange transactions, in which the City receives value without directly giving equal value in return, include income taxes, property taxes, grants, entitlements and donations. On an accrual basis, revenue from income taxes is recognized in the period in which the income is earned. Revenue from property taxes is recognized in the year for which the taxes are levied (see Note 6). Revenue from grants, entitlements and donations is recognized in the year in which all eligibility requirements have been satisfied. Eligibility requirements include timing requirements, which specify the year when the resources are required to be used or the year when use is first permitted, matching requirements, in which the City must provide local resources to be used for a specified purpose, and expenditure requirements, in which the resources are provided to the City on a reimbursement basis. On a modified accrual basis, revenue from non-exchange transactions must also be available before it can be recognized.

Under the modified accrual basis, the following revenue sources are considered to be both measurable and available at year-end: income tax, state-levied locally shared taxes (including gasoline tax and motor vehicle license tax), fines and forfeitures, licenses and permits, interest, grants and entitlements and rentals.

Deferred Outflows/Inflows of Resources

In addition to assets, the statements of financial position will sometimes report a separate section for deferred outflows of resources. Deferred outflows of resources represent a consumption of net position that applies to a future period and will not be recognized as an outflow of resources (expense/expenditure) until then. For the City, deferred outflows of resources are reported on the government-wide statement of net position for pension. A deferred charge on refunding results from the difference in the carrying value of refunded debt and its reacquisition price. The deferred outflows of resources related to pension are explained in Note 11.

In addition to liabilities, the statements of financial position report a separate section for deferred inflows of resources. Deferred inflows of resources represent an acquisition of net position that applies to a future period and will not be recognized until that time. For the City, deferred inflows of resources include property taxes, pension, and unavailable revenue. Property taxes represent amounts for which there is an enforceable legal claim as of December 31, 2017, but which were levied to finance year 2018 operations. These amounts have been recorded as a deferred inflow on both the government-wide statement of net position and governmental fund financial statements. Unavailable revenue is reported only on the governmental funds balance sheet and represents receivables which will not be collected within the available period. For the City, unavailable revenue includes delinquent property taxes, municipal income taxes, special assessments, intergovernmental, and charges for services. These amounts are deferred and recognized as an inflow of resources in the period the amounts become available. Deferred inflows of resources related to pension are reported on the government-wide statement of net position. (See Note 11)

Expenses/Expenditures

On the accrual basis of accounting, expenses are recognized at the time they are incurred.

The measurement focus of governmental fund accounting is on decreases in net financial resources (expenditures) rather than expenses. Expenditures are generally recognized in the accounting period in which the related fund liability is incurred, if measurable. Allocations of cost, such as depreciation and amortization, are not recognized in governmental funds.

City of Brook Park, Ohio

Notes to the Basic Financial Statements (continued)

For The Year Ended December 31, 2017

Note 2: Summary of Significant Accounting Policies (continued)

E. Budgetary Process

An annual appropriated budget is legally required to be prepared for all funds of the City other than agency funds. Council passes appropriations at the department level by object. Line item appropriations may be transferred between the accounts with the approval of the Finance Director and respective department head. Council must approve any revisions in the budget that alter total fund appropriations. The following are the procedures used by the City in establishing the budgetary data reported in the basic financial statements:

Tax Budget

A tax budget of estimated revenue and expenditures for all funds other than agency funds is submitted to the County Auditor, as Secretary of the County Budget Commission, by July 20th of each year, for the period January 1 to December 31 of the following year.

Estimated Resources

The County Budget Commission determines if the budget substantiates a need to levy the full amount of authorized property tax rates and reviews revenue estimates. The Commission certifies its actions to the City by September 1. As part of this certification, the City receives the official certificate of estimated resources, which states the projected revenue of each fund. Prior to December 31, the City must revise its budget so that the total contemplated expenditures from any fund during the ensuing fiscal year will not exceed the amount available as stated in the certificate of estimated resources. The revised budget then serves as the basis for the annual appropriations measure.

On or about January 1 the certificate of estimated resources is amended to include unencumbered fund balances at December 31. Further amendments may be made during the year if the Finance Director determines that revenue to be collected will be greater than or less than the prior estimates and the budget commission considers the revised estimates to be reasonable. The amounts reported in the budgetary statements as original represent the amounts in the first official certificate of estimated resources issued during 2017. The amounts reported in the budgetary statements as final reflect the amounts in the final amended official certificate of estimated resources issued during 2017.

Annual Estimate

The Mayor, with the assistance of the Finance Director, is required by Charter to submit to Council, on or before December 1 of each fiscal year, an estimate of the revenues and expenditures of each fund of the City for the next succeeding fiscal year. The annual estimate serves as the basis for appropriations (the appropriated budget) in each fund.

City of Brook Park, Ohio

Notes to the Basic Financial Statements (continued)

For The Year Ended December 31, 2017

Note 2: Summary of Significant Accounting Policies (continued)

E. Budgetary Process (continued)

Appropriations

An appropriation ordinance (the appropriated budget) to control the level of expenditures for all funds must be legally enacted on or about January 1. Appropriations may not exceed estimated resources as established in the official Amended Certificate of Estimated Resources. Supplemental appropriations may be adopted by Council action. During the year, several supplemental appropriation measures were necessary. The amounts reported as the original budgeted amounts in the budgetary statements reflect the first appropriated budget for each fund that covered the entire year, including amounts automatically carried over from prior years. The amounts reported as the final budgeted amounts in the statements of budgetary comparisons represent the final appropriation amounts, including all amendments and modifications.

Lapsing of Appropriations

At the close of each year, the unencumbered balance of each appropriation reverts to the respective fund from which it was appropriated and becomes subject to future appropriations. The encumbered appropriation balance is carried over for the subsequent year's expenditures and is re-appropriated.

Budgeted Level of Expenditure

Administrative control is maintained through the establishment of detailed line-item budgets. Appropriated funds may not be expended for purposes other than those designated in the appropriation ordinance without authority from Council. Expenditures plus encumbrances may not legally exceed appropriations at the level of appropriation adopted by Council. For all funds, Council appropriations are made at the department level by object. The appropriations set by Council must remain fixed unless amended by Council ordinance. More detailed appropriation allocations may be made by the Finance Director as long as the allocations are within Council's appropriated amount.

Encumbrances

As part of formal budgetary control, purchase orders, contracts, and other commitments for the expenditure of monies are encumbered and recorded as the equivalent of expenditures on the non-GAAP budgetary basis in order to reserve that portion of the applicable appropriation and determine and maintain legal compliance. The Ohio Revised Code prohibits expenditures plus encumbrances from exceeding appropriations. Encumbrances outstanding at year-end are reported as part of restricted, committed, and assigned fund balances for subsequent-year expenditures of governmental funds.

City of Brook Park, Ohio

Notes to the Basic Financial Statements (continued)

For The Year Ended December 31, 2017

Note 2: Summary of Significant Accounting Policies (continued)

F. Pooled Cash and Cash Equivalents

To improve cash management, cash received by the City is pooled. Monies for all funds are maintained in this pool. Individual fund integrity is maintained through City records. Each fund's interest in the pool is presented as "equity in pooled cash and cash equivalents" on the balance sheet.

The City has segregated bank accounts for monies held separate from the City's cash pool. These depository accounts are presented on the Statement of Fiduciary Net Position as "cash and cash equivalents in segregated accounts" since they are not required to be deposited into the City's treasury and are related to the City's mayor's court. The City has cash with escrow agent accounts as a result of money being set aside for vehicles that the City has not received as a part of their capital leases agreements that were entered into during 2017.

Investments are reported at fair value which is based on quoted market prices. Non-participating contracts such as non-negotiable certificates of deposits are reported at cost.

During fiscal year 2017, the City invested in STAR Ohio. STAR Ohio (the State Treasury Asset Reserve of Ohio), is an investment pool managed by the State Treasurer's Office which allows governments within the State to pool their funds for investment purposes.

STAR Ohio is not registered with the SEC as an investment company, but has adopted Governmental Accounting Standards Board (GASB), Statement No. 79 "Certain External Investment Pools and Pool Participants." The City measures their investment in STAR Ohio at the net asset value (NAV) per share provided by STAR Ohio. The NAV per share is calculated on an amortized cost basis that provides a NAV per share that approximates fair value.

For 2017, there were no limitation or restrictions on any participant withdrawals due to redemption notice periods, liquidity fees, or redemption gates. However, notice must be given 24 hours in advance of all deposits and withdrawals exceeding \$25 million. STAR Ohio reserves the right to limit the transaction to \$50 million, requiring the excess amount to be transacted the following business day(s), but only to the \$50 million limit. All accounts of the participant will be combined for these purposes.

The City's policy is to hold investments until market values equal or exceed cost.

Interest allocation is determined by the Ohio Constitution, state statutes, and local ordinances adopted under City Charter. Under these provisions, City funds required to receive interest allocations are: 1) those which receive proceeds from the sale of notes and/or bonds and 2) those which receive distributions of state gasoline tax and motor vehicle licenses fees (street maintenance and state highway special revenue funds). All remaining interest is allocated to the general fund. Legally, proprietary funds generally do not receive interest. Interest revenue credited to the General Fund during 2017 amounted to \$92,788, which includes \$54,702 assigned from other funds.

City of Brook Park, Ohio

Notes to the Basic Financial Statements (continued)

For The Year Ended December 31, 2017

Note 2: Summary of Significant Accounting Policies (continued)

G. Inventory

Inventories are stated at cost, on the first-in, first-out basis. The purchase method is used to account for inventories. Under the purchase method, inventories are recorded as expenditures in the governmental fund types when purchased; however, material amounts of inventories at period-end are reported as assets of the respective fund, which are equally offset in the non-spendable component of fund balance which indicates they are unavailable for appropriation even though they are a component of reported assets. Inventory consists of expendable supplies.

H. Prepaid Items

Payments made to vendors for services that will benefit periods beyond December 31, 2017, are recorded as prepaid items using the allocation method by recording a current asset for the prepaid amount and reflecting the expenditure/expense in the year in which it was consumed.

I. Receivables

Receivables at December 31, 2017 consist of taxes, intergovernmental, accounts (billings for user charged services), special assessments, and accrued interest on investments. All are deemed collectible in full.

J. Capital Assets

General capital assets are those assets not specifically related to activities reported in the proprietary funds. These assets generally result from expenditures in the governmental funds. These assets are reported in the governmental activities column of the government-wide statement of net position but are not reported in the fund financial statements.

All capital assets are capitalized at cost (or estimated historical cost) and updated for additions and disposals during the year. Donated capital assets are recorded at their acquisition value as of the date received. The City maintains a capitalization threshold of five thousand dollars. The City's infrastructure consists of bridges, culverts, curbs, sidewalks, storm sewers, streets, irrigation systems and water and sewer lines. Improvements are capitalized; the costs of normal maintenance and repairs that do not add to the value of the asset or materially extend an asset's life are not. Interest incurred during the construction of capital assets is also capitalized.

All capital assets are depreciated except for land and construction in progress. Improvements are depreciated over the remaining useful lives of the related capital assets. Useful lives for infrastructure were estimated based on the City's historical records of necessary improvements and replacement. Depreciation is computed using the straight-line method over the following useful lives:

<u>Description</u>	<u>Estimated Lives</u>
Buildings and Improvements	50 years
Machinery and Equipment	10 to 15 years
Vehicles	6 to 10 years
Infrastructure	25 to 50 years

City of Brook Park, Ohio

Notes to the Basic Financial Statements (continued)

For The Year Ended December 31, 2017

Note 2: Summary of Significant Accounting Policies (continued)

K. Interfund Balances

On fund financial statements, outstanding interfund loans and unpaid amounts for interfund services are reported as “interfund receivables/payables”. Interfund loans which do not represent available expendable resources would be offset by a component of fund balance. Interfund balance amounts are eliminated in the statement of net position.

L. Compensated Absences

The City reports compensated absences in accordance with the provisions of GASB No. 16, “*Accounting for Compensated Absences*.” Vacation benefits are accrued as a liability as the benefits are earned if the employees’ rights to receive compensation are attributable to services already rendered and it is probable that the employer will compensate the employees for the benefits through paid time off or some other means.

Sick leave benefits are accrued as a liability using the vesting method. The liability includes the employees who are currently eligible to receive termination benefits and those that the City has identified as probable of receiving payment in the future. The amount is based on accumulated sick leave and employee wage rates at fiscal year-end taking into consideration any limits specified in the City’s termination policy.

Additionally, certain salary related payments associated with the payment of compensated absences have been accrued.

The entire compensated absence liability is reported on the government-wide financial statements. A liability for the amounts is reported in governmental funds only if they have matured, for example, as a result of employee resignations and retirements.

M. Pensions

For purposes of measuring the net pension liability/(asset), deferred outflows of resources and deferred inflows of resources related to pensions, and pension expense, information about the fiduciary net position of the pension plans and additions to/deductions from their fiduciary net position have been determined on the same basis as they are reported by the pension systems. For this purpose, benefit payments (including refunds of employee contributions) are recognized when due and payable in accordance with the benefit terms. The pension systems report investments at fair value.

N. Accrued Liabilities and Long-Term Obligations

All payables, accrued liabilities and long-term obligations are reported in the government-wide financial statements.

In general, governmental fund payables and accrued liabilities that, once incurred, are paid in a timely manner and in full from current financial resources are reported as obligations of the funds. However, claims and judgments and compensated absences that will be paid from governmental funds are reported as a liability in the fund financial statements only to the extent that they are due for payment during the current year. Bonds, capital leases and long-term loans are recognized as a liability on the fund financial statements when due.

City of Brook Park, Ohio

Notes to the Basic Financial Statements (continued)

For The Year Ended December 31, 2017

Note 2: Summary of Significant Accounting Policies (continued)

O. Fund Balance

Fund balance is divided into five classifications based primarily on the extent to which the City is bound to observe constraints imposed upon the use of the resources in the governmental funds. The classifications are as follows:

Nonspendable – The nonspendable fund balance classification includes amounts that cannot be spent because they are not spendable in form, or legally or contractually required to be maintained intact. The “not in spendable form” criterion includes items that are not expected to be converted to cash. It also includes the long-term amount of loans receivable, as well as property acquired for resale, unless the use of the proceeds from the collection of those receivables or from the sale of those properties is restricted, committed, or assigned.

Restricted – Fund balance is reported as restricted when constraints placed on the use of resources are either externally imposed by creditors (such as through debt covenants), grantors, contributors, or laws or regulations of other governments or is imposed by law through constitutional provisions.

Committed – The committed fund balance classification includes amounts that can be used only for the specific purposes imposed by a formal action (ordinance) of the City’s Council. Those committed amounts cannot be used for any other purpose unless the City’s Council removes or changes the specified use by taking the same type of action (ordinance) it employed to previously commit those amounts. Committed fund balance also incorporates contractual obligations to the extent that existing resources in the fund have been specifically committed for use in satisfying those contractual requirements.

Assigned – Amounts in the assigned fund balance classification are intended to be used by the City for specific purposes but do not meet the criteria to be classified as restricted or committed. In governmental funds other than the general fund, assigned fund balance represents the remaining amount that is not restricted or committed. These amounts are assigned by the City Council. In the general fund, assigned amounts would represent intended uses established by policies of the City Council or a City official delegated that authority by City Charter or ordinance, or by State statute. State statute authorizes the finance director to assign fund balance for purchases on order provided such amounts have been lawfully appropriated.

Unassigned – Unassigned fund balance is the residual classification for the general fund and includes all spendable amounts not contained in the other classifications. In the other governmental funds, the unassigned classification is used only to report a deficit balance resulting from overspending for specific purposes for which amounts had been restricted, committed, or assigned.

The City applies restricted resources first when expenditures are incurred for purposes for which either restricted or unrestricted (committed, assigned, and unassigned) amounts are available. Similarly, within unrestricted fund balance, committed amounts are reduced first followed by assigned, and then unassigned amounts when expenditures are incurred for purposes for which amounts in any of the unrestricted fund balance classifications could be used.

City of Brook Park, Ohio

Notes to the Basic Financial Statements (continued)

For The Year Ended December 31, 2017

Note 2: Summary of Significant Accounting Policies (continued)

P. Net Position

Net position is the residual amount when comparing assets and deferred outflows of resources to liabilities and deferred inflows of resources. The net investment in capital assets component of net position consists of capital assets, net of accumulated depreciation, reduced by the outstanding balances of any borrowing used for the acquisition, construction or improvement of those assets along with any related deferred outflows/inflows of resources. The restricted component of net position is reported when there are limitations imposed on their use either through the enabling legislation adopted by the City or through external restrictions imposed by creditors, grantors or laws or regulations of other governments. As of December 31, 2017, the City did not have net position restricted by enabling legislation.

The City applies restricted resources when an expense is incurred for purposes for which both restricted and unrestricted net position are available.

Q. Operating Revenues and Expenses

Operating revenues are those revenues that are generated directly from the primary activity of the proprietary funds. For the City, these revenues are charges for services for the self-insurance program. Operating expenses are necessary costs incurred to provide the service that is the primary activity of the fund. All revenues and expenses not meeting this definition are reported as non-operating.

R. Grants and Intergovernmental Revenues

Federal grants and assistance awards made on the basis of entitlement periods are recorded as intergovernmental receivables and revenues when entitlement occurs. Federal reimbursement-type grants are recorded as intergovernmental receivables and revenues in the period when all applicable eligibility requirements have been met and the resources are available.

S. Interfund Activity

Exchange transactions between funds are reported as revenues in the seller funds and as expenditures/expenses in the purchaser funds. Flows of cash or goods from one fund to another without a requirement for repayment are reported as interfund transfers. Interfund transfers are reported as other financing sources/uses in governmental funds and after nonoperating revenues/expenses in proprietary funds. Repayments from funds responsible for particular expenditures/expenses to the funds that initially paid for them are not presented on the financial statements.

T. Extraordinary and Special Items

Extraordinary items are transactions or events that are both unusual in nature and infrequent in occurrence. Special items are transactions or events that are within the control of the City Administration and that are either unusual in nature or infrequent in occurrence. Neither extraordinary nor special items had occurred in 2017.

City of Brook Park, Ohio

Notes to the Basic Financial Statements (continued)

For The Year Ended December 31, 2017

Note 2: Summary of Significant Accounting Policies (continued)

U. Estimates

The preparation of the financial statements in conformity with generally accepted accounting principles requires management to make estimates and assumptions that affect the amounts reported in the financial statements and accompanying notes. Actual results may differ from those estimates.

Note 3: Changes in Accounting Principles

For the fiscal year ended December 31, 2017, the City has implemented Governmental Accounting Standards Board (GASB) Statement No. 74, *Financial Reporting for Postemployment Benefit Plans Other Than Pension Plans*, GASB Statement No. 80, *Blending Requirements for Certain Component Units-an amendment of GASB Statement No. 14*, GASB Statement No. 81, *Irrevocable Split-Interest Agreements*, GASB Statement No. 82, *Pension Issues-an amendment of GASB Statements No. 67, No. 68, and No. 73*. GASB Statement No. 78, *Pensions Provided through Certain Multiple-Employer Defined Benefit Pension Plans*.

GASB Statement No. 74, *Financial Reporting for Postemployment Benefit Plans Other Than Pension Plans*. The objective of this Statement is to improve the usefulness of information about postemployment benefits other than pensions (other postemployment benefits or OPEB) included in the general purpose external financial reports of state and local governmental OPEB plans for making decisions and assessing accountability. The implementation of GASB Statement No. 74 did not have an effect on the financial statements of the City.

GASB Statement No. 80, *Blending Requirements for Certain Component Units-an amendment of GASB Statement No. 14*. The objective of this Statement is to improve financial reporting by clarifying the financial statement presentation requirements for certain component units. This Statement amends the blending requirements established in paragraph 53 of Statement No. 14, *The Financial Reporting Entity, as amended*. The implementation of GASB Statement No. 80 did not have an effect on the financial statements of the City.

GASB Statement No. 81, *Irrevocable Split-Interest Agreements*. The object of this statement is to improve accounting and financial reporting for irrevocable split-interest agreements by providing recognition and measurement guidance for situations in which a government is a beneficiary of the agreement. The implementation of GASB Statement No. 81 did not have an effect on City's beginning net position.

GASB Statement No. 82, *Pension Issues-an amendment of GASB Statements No. 67, No. 68, and No. 73*. The objective of this Statement is to address certain issues that have been raised with respect to Statements No. 67, *Financial Reporting for Pension Plans*, No. 68, *Accounting and Financial Reporting for Pensions*, and No. 73, *Accounting and Financial Reporting for Pensions and Related Assets That Are Not within the Scope of GASB Statement 68, and Amendments to Certain Provisions of GASB Statements 67 and 68*. Specifically, this Statement addresses issues regarding (1) the presentation of payroll-related measures in required supplementary information, (2) the selection of assumptions and the treatment of deviations from the guidance in an Actuarial Standard of Practice for financial reporting purposes, and (3) the classification of payments made by employers to satisfy employee (plan member) contribution requirements. The implementation of GASB Statement No. 82 did not have an effect on City's beginning net position.

City of Brook Park, Ohio

Notes to the Basic Financial Statements (continued)

For The Year Ended December 31, 2017

Note 4: Budgetary Basis of Accounting

While the City is reporting financial position, results of operations, and changes in fund balances on the basis of generally accepted accounting principles (GAAP), the budgetary basis as provided by law is based upon accounting for certain transactions on a basis of cash receipts, disbursements, and encumbrances.

The Statements of Revenues, Expenditures and Changes in Fund Balances – Budget (Non-GAAP Budgetary Basis) and Actual presented for the General Fund is presented on the budgetary basis to provide a meaningful comparison of actual results with the budget. The major differences between the budget basis and the GAAP basis are that:

- (a) Revenues are recorded when received in cash (budget basis) as opposed to when susceptible to accrual (GAAP basis);
- (b) Expenditures are recorded when paid in cash (budget basis) as opposed to when the liability is incurred (GAAP basis);
- (c) Encumbrances are treated as expenditures (budget) rather than as a part of restricted, committed, and assigned fund balances (GAAP);
- (d) Some funds are included in the General Fund (GAAP basis), but have separate legally adopted budgets (budget basis).

The following table summarizes the adjustments necessary to reconcile the GAAP basis statements to the budgetary basis statements for the General Fund.

<u>Net Change in Fund Balance</u>	
	<u>General</u>
GAAP Basis	\$ (828,479)
<u>Increase (Decrease) Due to:</u>	
Revenue Accruals	195,174
Expenditure Accruals	(124,474)
Funds with Separate Legally Adopted Budget	(484)
Outstanding Encumbrances	<u>(270,439)</u>
Budget Basis	<u>\$ (1,028,702)</u>

Note 5: Deposits and Investments

State statutes classify monies held by the City into three categories. Active deposits are public deposits necessary to meet current demands on the treasury. Such monies must be maintained either as cash in the City treasury, in commercial accounts payable or withdrawable on demand, including negotiable order of withdrawal (NOW) accounts, or in money market deposit accounts.

Inactive deposits are monies identified as not required for use within the current five-year period of designation of depositories. Inactive deposits must either be evidenced by certificates of deposit maturing not later than the end of the current period of designation of depositories, or by savings or deposit account including, but not limited to, passbook accounts.

City of Brook Park, Ohio

Notes to the Basic Financial Statements (continued)

For The Year Ended December 31, 2017

Note 5: Deposits and Investments (continued)

Interim monies are those monies which are not needed for immediate use but which will be needed before the end of the current period of designation of depositories. Interim monies may be deposited or invested in the following securities:

1. United States Treasury notes, Bills, Bonds, or any other obligation or security issued by the United States Treasury or any other obligation guaranteed as to principal and interest by the United States;
2. Bonds, notes, debentures, or any other obligations or securities issued by any federal government agency or instrumentality, including but not limited to, the Federal National Mortgage Association, Federal Home Loan Bank, Federal Farm Credit Bank, Federal Home Loan Mortgage Corporation, Government National Mortgage Association, and Student Loan Marketing Association. All federal agency securities shall be direct issuances of federal government agencies or instrumentalities;
3. Written repurchase agreements in the securities listed above provided that the fair value of the securities subject to the repurchase agreement must exceed the principal value of the agreement by at least two percent and be marked to market daily;
4. Investment grade obligations of state and local governments, and public authorities;
5. No-load money market mutual funds consisting exclusively of obligations described in division (1) or (2) of this section and repurchase agreements secured by such obligations, provided that investments in securities described in this division are made only through eligible institutions; and
6. The State Treasurer's investment pool (STAR Ohio).

Investments in stripped principal or interest obligations, reverse repurchase agreements and derivatives are prohibited. The issuance of taxable notes for the purpose of arbitrage, the use of leverage and short selling are also prohibited. An investment must mature within five years from the date of purchase unless matched to a specific obligation or debt of the City and must be purchased with the expectation that it will be held to maturity.

Investments may only be made through specified dealers and institutions. Payment for investments may be made only upon delivery of the securities representing the investments to the treasurer or qualified trustee or, if the securities are not represented by a certificate, upon receipt of confirmation of transfer from the custodian.

City of Brook Park, Ohio

Notes to the Basic Financial Statements (continued)

For The Year Ended December 31, 2017

Note 5: Deposits and Investments (continued)

A. Deposits

At year-end, the carrying amount of the City's deposits was \$12,087,402 (including \$4,030 of petty cash, \$439,455 of cash with escrow agent, \$45,388 of segregated accounts and \$12,531 in STAR Plus) and the bank balance was \$11,996,854. As of December 31, 2017, \$262,531 of the City's bank balances were covered by Federal depository insurance and the remaining \$11,734,323 was exposed to custodial credit risk because it was uninsured and collateralized. Although the securities were held by the pledging institution's trust department and all statutory requirements for the investment of money had been followed, noncompliance with Federal requirements could potentially subject the City to a successful claim by the FDIC.

The City has no deposit policy for custodial risk beyond the requirements of State statute. Ohio law requires that deposits be either insured or protected by:

Eligible securities pledged to the City and deposited with a qualified trustee by the financial institution as security for repayment whose fair value at all times shall be at least 105 percent of the deposits being secured; or

Participation in the Ohio Pooled Collateral System (OPCS), a collateral pool of eligible securities deposited with a qualified trustee and pledged to the Treasurer of State to secure the repayment of all public monies deposited in the financial institution. OPCS requires the total fair value of the securities pledged to be 102 percent of the deposits being secured or a rate set by the Treasurer of State. The City's financial institution had enrolled in OPCS as of December 31, 2017.

As of December 31, 2017, The City's financial institution for deposits was a member of the Ohio Pooled Collateral System.

B. Investments

Investments are reported at Net Asset Value. As of December 31, 2017, the City had the following investments:

<u>Investment Type</u>	<u>NAV</u>	<u>Credit Rating (*)</u>	<u>Investment Maturities (in Years)</u>
STAR Ohio	\$ 9,831,563	AAAm	\$ 9,831,563
Total Investments	9,831,563		\$ 9,831,563

* Credit Ratings were obtained from Standard & Poor's, respectively, for all investments.

The City has categorized its fair value measurements within the fair value hierarchy established by generally accepted accounting principles. The hierarchy is based on the valuation inputs used to measure the fair value of the asset. Level 1 inputs are quoted prices in active markets for identical assets. Level 2 inputs are significant other observable inputs; Level 3 inputs are significant unobservable inputs.

City of Brook Park, Ohio

Notes to the Basic Financial Statements (continued)

For The Year Ended December 31, 2017

Note 5: Deposits and Investments (continued)

Interest Rate Risk arises because potential purchasers of debt securities will not agree to pay face value for those securities if interest rates subsequently increase. The City's investment policy addresses interest rate risk requiring that the City's investment portfolio be structured so that securities mature to meet cash requirements for ongoing operations and/or long-term debt payments, thereby avoiding that need to sell securities on the open market prior to maturity and by investing operating funds primarily in short-term investments. The City's investment policy also limits security purchases to those that mature in five years unless specifically matched to a specific cash flow. To date, no investments have been purchased with a life greater than five years.

Custodial Risk for investments is the risk that, in the event of the failure of the counterparty to a transaction, the City will not be able to recover the value of investment or collateral securities that are in the possession of an outside party. All financial institutions and broker/dealers who desire to become qualified for investment transactions with the City must meet a set of prescribed standards and be periodically reviewed.

Credit Risk is addressed by the City's investment policy by the requirements that all investments are authorized by Ohio Revised Code and that the portfolio be diversified both by types of investment and issuer. The investments of the City are registered and the credit rating provided by Standard & Poor's is provided in the table above.

Concentration of Credit Risk is defined by the Governmental Accounting Standards Board as five percent or more in the securities of a single issuer. The City's investment policy requires diversification of the portfolio but does not indicate specific percentage allocations. The City's investment in STAR Ohio represents 100.00 percent of the City's total investments.

Note 6: Receivables

Receivables at December 31, 2017 consisted primarily of taxes, intergovernmental receivables arising from grants, entitlements or shared revenues, accounts, special assessments and interest on investments. All receivables are considered fully collectible.

A. Property Tax

Property taxes include amounts levied against all real, public utility, and tangible personal property located in the City. Taxes collected on real property (other than public utility) in one calendar year are levied in the preceding calendar year on assessed values as of January 1 of that preceding year, the lien date. Assessed values are established by state statute at 35 percent of appraised market value. All property is required to be revalued every six years. The last revaluation was completed in 2016. Real property taxes are payable annually or semiannually. The first payment is due December 31, with the remainder payable by June 20.

Taxes collected on tangible personal property (other than public utility) in one calendar year are levied in the prior calendar year on assessed values during and at the close of the most recent fiscal year of the taxpayer that ended on or before March 31 of that calendar year, and at the tax rates determined in the preceding year.

Tangible personal property used in business (except for public utilities) is currently assessed for *ad valorem* taxation purposes at 25 percent of its true value. The tangible personal property tax has been phased out and the City is only receiving residual amounts from delinquent tangible personal property taxes.

City of Brook Park, Ohio

Notes to the Basic Financial Statements (continued)

For The Year Ended December 31, 2017

Note 6: Receivables (continued)

A. Property Tax (Continued)

Amounts paid by multi-county taxpayers are due September 20. Single county taxpayers may pay annually or semiannually. If paid annually, payment is due April 30; if paid semiannually, the first payment is due April 30; with the remainder payable by September 20.

Public utility real and tangible personal property taxes collected in one calendar year are levied in the preceding calendar year on assessed values determined as of December 31 of the second year preceding the tax collection year, the lien date. Certain public utility tangible personal property currently is assessed at 88 percent of its true value. Public utility property taxes are payable on the same dates as real property taxes described previously.

The County Fiscal Officer collects property taxes on behalf of all taxing districts in the county, including the City of Brook Park. The County Fiscal Officer periodically remits to the City its portion of the taxes collected.

The full tax rate for all City operations for the year ended December 31, 2017, was \$4.75 per \$1,000 of assessed value. The assessed values of real and tangible personal property upon which 2017 property tax receipts were based are as follows:

<u>Category</u>	<u>Assessed Value</u>
Real Estate	\$ 398,592,050
Public Utility	12,450,870
Total	<u>\$ 411,042,920</u>

B. Income Tax

The City levies and collects a 2 percent income tax on all income earned within the City as well as on income of residents earned outside the City. In the latter case, the City allows a credit of 100 percent of the tax paid to another municipality, not to exceed the amount owed. Employers within the City are required to withhold income tax on employee earnings and remit the tax to the City at least quarterly. Corporations and other individual taxpayers are also required to pay their estimated tax at least quarterly and file a final return annually. The City, by ordinance, allocates income tax revenues and expenditures for collecting, administering, and enforcing the tax to the General and Capital Improvements Capital Projects Funds, at eighty and twenty percent, respectively.

The Capital Improvements Capital Projects Fund further allocates income taxes to other project-based capital projects funds, as transfers, through the budgetary process.

City of Brook Park, Ohio

Notes to the Basic Financial Statements (continued)

For The Year Ended December 31, 2017

Note 6: Receivables (continued)

C. Intergovernmental

A summary of the principal items of intergovernmental receivables follows:

	<u>Amounts</u>
Local government funds	\$ 192,700
Auto registration fees	90,715
Homestead and rollback	110,977
Gasoline and excise tax	341,772
Permissive tax	3,494
City of Cleveland (share of OPWC loan)	760,240
OPWC Grant Reimbursement	31,949
Miscellaneous Grant	<u>14,400</u>
Total	<u>\$ 1,546,247</u>

This space is intentionally left blank

City of Brook Park, Ohio

Notes to the Basic Financial Statements (continued)

For The Year Ended December 31, 2017

Note 7: Capital Assets

	Balances 12/31/2016	Additions	Disposals	Balances 12/31/2017
Governmental Activities				
Nondepreciable Assets:				
Land	\$ 4,896,683	\$ 30,240	\$ -	\$ 4,926,923
Construction in progress	4,366,746	10,057,490	(1,042,722)	13,381,514
Total Nondepreciable Assets	<u>9,263,429</u>	<u>10,087,730</u>	<u>(1,042,722)</u>	<u>18,308,437</u>
Depreciable Assets:				
Buildings and Improvements	17,855,885	25,747	-	17,881,632
Improvements Other than Buildings	3,193,623	-	-	3,193,623
Machinery and Equipment	5,191,211	77,647	-	5,268,858
Furniture and Fixtures	210,094	-	-	210,094
Vehicles	8,695,385	2,046,176	(647,972)	10,093,589
Infrastructure:				
Streets	54,169,534	683,714	(67,945)	54,785,303
Sewers	26,576,423	-	-	26,576,423
Water Lines	1,107,963	358,988	-	1,466,951
Total Depreciable Assets	<u>117,000,118</u>	<u>3,192,272</u>	<u>(715,917)</u>	<u>119,476,473</u>
Less Accumulated Depreciation				
Buildings and Improvements	(9,728,721)	(360,228)	-	(10,088,949)
Improvements Other than Buildings	(2,327,836)	(106,501)	-	(2,434,337)
Machinery and Equipment	(3,779,322)	(258,398)	-	(4,037,720)
Furniture and Fixtures	(186,763)	(5,042)	-	(191,805)
Vehicles	(6,295,238)	(421,049)	374,006	(6,342,281)
Infrastructure:				
Streets	(16,556,389)	(1,732,161)	63,090	(18,225,460)
Sewers	(9,312,843)	(531,528)	-	(9,844,371)
Water Lines	(385,592)	(20,286)	-	(405,878)
Total Accumulated Depreciation	<u>(48,572,704)</u>	<u>(3,435,193) *</u>	<u>437,096</u>	<u>(51,570,801)</u>
Total Depreciable Assets, Net	<u>68,427,414</u>	<u>(242,921)</u>	<u>(278,821)</u>	<u>67,905,672</u>
Governmental Activities Capital Assets, Net	<u>\$ 77,690,843</u>	<u>\$ 9,844,809</u>	<u>\$ (1,321,543)</u>	<u>\$ 86,214,109</u>

* Depreciation was charged to governmental activities as follows:

Security of Persons and Property:	
Police and Others	\$ 163,950
Fire	174,155
Public Health and Welfare	5,546
Leisure Time Activities	312,616
Community Development	22,361
Public Works	901,904
Transportation	1,683,263
General Government	171,398
Total Depreciation Expense	<u>\$ 3,435,193</u>

City of Brook Park, Ohio

Notes to the Basic Financial Statements (continued)

For The Year Ended December 31, 2017

Note 8: Long-Term Obligations

The original issue date, interest rates, and original issuance amount for each of the City's general obligation bonds follow:

	Original Issuance Date	Interest Rate	Original Issuance Amount
General Obligation Bonds:			
Laich Street Improvements	2004	2% - 3.7%	\$ 775,000
Heatherwood Dr. Reconstruction	2011	2% - 3.4%	905,000
Sheldon Rd. Waterline Replacement	2011	2% - 3.4%	800,000
Various Purpose Improvement Bonds:			
Engle Road Resurfacing	2013	2% - 4.75%	1,835,000
Engle Road Sanitary Sewer Replacement	2013	2% - 4.75%	1,965,000
Smith Road Sanitary Sewer	2013	2% - 4.75%	1,720,000
Energy Conservation Improvement Bonds	2017	1% - 4%	4,980,000

Changes in long-term debt activity for the year ended December 31, 2017 was as follows:

	Balances 12/31/2016	Issued	Retired	Balances 12/31/2017	Amounts Due in One Year
General Obligation Bonds:					
Laich Street Improvements	\$ 385,000	\$ -	\$ 40,000	\$ 345,000	\$ 45,000
Heatherwood Drive Reconstruction	645,000	-	55,000	590,000	60,000
Sheldon Rd. Waterline Replacement	565,000	-	50,000	515,000	50,000
Various Purpose Improvement Bonds, Series 2013:					
Engle Road Resurfacing Project	1,540,000	-	105,000	1,435,000	110,000
Engle Road Sanitary Sewer Replacement Project	1,755,000	-	75,000	1,680,000	80,000
Smith Road Sanitary Sewer Project	1,540,000	-	65,000	1,475,000	70,000
Energy Conservation Improvement Project	-	4,980,000	100,000	4,880,000	180,000
Total General Obligation Bonds	<u>6,430,000</u>	<u>4,980,000</u>	<u>490,000</u>	<u>10,920,000</u>	<u>595,000</u>
Capitalized Lease Agreements:					
Automated Rubbish Vehicles and Cans	449,965	-	223,181	226,784	226,784
Safety Forces Vehicles	-	261,980	89,363	172,617	85,306
Sewer Vector	-	936,158	142,827	793,331	124,977
Service Equipment	-	148,340	50,449	97,891	48,413
Various Vehicles	-	650,845	221,043	429,802	212,815
Total Capital Leases	<u>449,965</u>	<u>1,997,323</u>	<u>726,863</u>	<u>1,720,425</u>	<u>698,295</u>

(continued)

City of Brook Park, Ohio

Notes to the Basic Financial Statements (continued)

For The Year Ended December 31, 2017

Note 8: Long-Term Obligations (continued)

	Balances		Balances		Amounts
	12/31/2016	Issued	Retired	12/31/2017	Due in One Year
Other Long-term Obligations:					
Unamortized Bond Premiums	\$ 224,127	\$ 219,628	\$ 23,492	\$ 420,263	\$ -
OPWC Loan - W. 150th Project	1,315,797	-	97,467	1,218,330	97,467
OPWC Loan - Smith/Hummel Rd	88,604	-	5,907	82,697	5,907
OPWC Loan Payable - Smith Rd. Sanitary Sewer	802,825	-	20,071	782,754	40,142
City of Berea OPWC loan - Eastland Rd.	581,675	-	32,315	549,360	32,315
Accrued Compensated Absences	1,967,879	439,403	277,835	2,129,447	315,185
Net Pension Liability:					
OPERS	6,950,154	2,474,244	-	9,424,398	-
OP&F	17,319,903	-	174,968	17,144,935	-
Total Net Pension Liability:	<u>24,270,057</u>	<u>2,474,244</u>	<u>174,968</u>	<u>26,569,333</u>	<u>-</u>
Total Other Long-term Obligations	<u>29,250,964</u>	<u>3,133,275</u>	<u>632,055</u>	<u>31,752,184</u>	<u>491,016</u>
Total Governmental Long-term Liabilities	<u>\$ 36,130,929</u>	<u>\$ 10,110,598</u>	<u>\$ 1,848,918</u>	<u>\$ 44,392,609</u>	<u>\$ 1,784,311</u>

General obligation bonds are direct obligations of the City for which its full faith and credit are pledged for repayment. In the event that income tax revenues are not sufficient to meet annual principal and interest requirements, the City has reserved the right to levy and assess a special assessment on the property. Revenues will be received in and the debt will be paid from the General Obligation Debt Service Fund.

During 2005, the Ohio Public Works Commission (OPWC) approved a loan to the City to finance a portion of the West 150th Street Improvement project. OPWC committed up to \$1,949,332 at a zero percent interest rate for twenty years. The City and the City of Cleveland have an agreement to share the debt service requirements of the OPWC loan. The City will pay 100 percent of the annual debt service requirements and the City of Cleveland will reimburse the City 65 percent of the annual debt service requirement. The City has recorded an intergovernmental receivable in the amount of \$760,240 to recognize the City of Cleveland's share of the loan.

During 2010, the Ohio Public Works Commission (OPWC) approved a loan to the City to finance a portion of the Smith/Hummel Sewer Improvement Project Phase II. OPWC has committed up to \$573,140 at a zero percent interest rate for twenty years. The City has completed the project but only utilized \$118,139 of total \$573,140 in loan proceeds from OPWC.

During 2011, the City issued \$1,705,000 in various purpose improvement bonds, series 2011 with interest rates ranging from 2.00 percent to 3.40 percent over the life of the bonds. The proceeds from these bonds were used to finance the reconstruction of Heatherwood Drive (\$905,000) and a waterline replacement on Sheldon Road (\$800,000). The bonds will mature in 2026.

On October 1, 2013, the City issued \$5,520,000 in various purpose improvement bonds, series 2013 with interest rates ranging from 2.00 percent to 4.75 percent over the life of the bonds. The proceeds from these bonds were used to finance the Engle Road resurfacing project (\$1,835,000), the Engle Road sanitary sewer replacement project (\$1,965,000), and the Smith Road sanitary sewer project (\$1,720,000). The bonds will be fully matured in 2033.

City of Brook Park, Ohio

Notes to the Basic Financial Statements (continued)

For The Year Ended December 31, 2017

Note 8: Long-Term Obligations (continued)

During 2015, the Ohio Public Works Commission (OPWC) approved a loan to the City of Berea to finance the Eastland Road Reconstruction Project. OPWC has committed up to \$1,900,900 at a zero percent interest rate for twenty years. The City, the City of Berea and the City of Middleburg Heights have an agreement to share the debt service requirements of the OPWC loan. The City of Berea will pay 100 percent of the annual debt service requirements; the City will reimburse the City of Berea 34 percent of the annual debt service requirement; the City of Middleburg Heights will reimburse the City of Berea 43 percent of the annual debt service requirement.

During 2017, the Ohio Public Works Commission (OPWC) finalized a loan to the City to finance a portion of the Smith Rd. Sanitary Sewer Improvement Project Phase III. OPWC has committed up to \$802,825 at a zero percent interest rate for twenty years.

On April 26, 2017 the City issued \$4,980,000 in Energy Conservation Improvement bonds with interest rates ranging from 1.00 percent to 4.00 percent over the life of the bonds. The proceeds from these bonds were used to finance the Community Center Project. The bonds will be fully matured in 2037.

Compensated absences are generally paid from the General Fund, Street Maintenance Special Revenue Fund, State Highway Special Revenue Fund, and Community Diversion Special Revenue Fund.

See Note 9 for additional information on capital leases. See Note 11 for additional information on Net Pension Liability.

The City's overall legal debt margin was \$31,841,983 at December 31, 2017.

Principal and interest requirements to retire long-term obligations outstanding at December 31, 2017 are as follows:

Year	General Obligation Bonds		OPWC Loans	Total
	Principal	Interest	Principal	
2018	595,000	392,338	175,831	1,163,169
2019	570,000	376,901	175,830	1,122,731
2020	590,000	361,563	175,831	1,127,394
2021	620,000	344,793	175,830	1,140,623
2022	645,000	324,413	175,831	1,145,244
2023-2027	3,345,000	1,277,244	879,147	5,501,391
2028-2032	2,770,000	681,424	629,574	4,080,998
2033-2037	1,785,000	162,225	245,267	2,192,492
Total	<u>\$ 10,920,000</u>	<u>\$ 3,920,901</u>	<u>\$ 2,633,141</u>	<u>\$ 17,474,042</u>

City of Brook Park, Ohio

Notes to the Basic Financial Statements (continued)

For The Year Ended December 31, 2017

Note 9: Capital Leases

The City has entered into lease agreements as lessee for financing which relate to various equipment and vehicles. These lease agreements qualify as capital leases for accounting purposes and therefore, have been recorded at the present value of their future minimum lease payments as of inception date.

	<u>Governmental Activities</u>
Assets:	
Machinery and equipment	\$ 732,150
Less: accumulated depreciation	<u>(408,784)</u>
Total	<u>\$ 323,366</u>
Vehicles	\$ 2,696,899
Less: accumulated depreciation	<u>(478,837)</u>
Total	<u>\$ 2,218,062</u>

The future minimum lease obligations and the net present value of these minimum lease payments as of December 31, 2017, were as follows:

<u>Year</u>	<u>Payments</u>
2018	734,928
2019	504,379
2020	142,827
Therein After	<u>428,481</u>
Total Minimum Lease Payments	1,810,615
Less: Amount Representing Interest	<u>(90,190)</u>
Present Value of Minimum Lease Payment	<u>\$ 1,720,425</u>

Note 10: Compensated Absences

Vacation leave is earned at rates which vary depending upon length of service and standard work week. Current policy credits vacation leave on the employee's anniversary date and allows the unused balance to be carried ninety days past the subsequent anniversary date. City employees are paid for earned, unused vacation leave at the time of termination of employment.

Sick leave is earned at the rate of four and six-tenths hours for every eighty hours worked for base employees, thirteen hours for firefighters, and ten hours for police patrol. Each employee with the City is paid for four eighths of the employee's earned unused sick leave upon retirement from the City, or the full balance may be transferred to another governmental agency.

City of Brook Park, Ohio

Notes to the Basic Financial Statements (continued)

For The Year Ended December 31, 2017

Note 11: Defined Benefit Pension Plans

A. Net Pension Liability

The net pension liability(Asset) reported on the statement of net position represents a liability to employees for pensions. Pensions are a component of exchange transactions—between an employer and its employees—of salaries and benefits for employee services. Pensions are provided to an employee—on a deferred-payment basis—as part of the total compensation package offered by an employer for employee services each financial period. The obligation to sacrifice resources for pensions is a present obligation because it was created as a result of employment exchanges that already have occurred.

The net pension liability represents the City's proportionate share of each pension plan's collective actuarial present value of projected benefit payments attributable to past periods of service, net of each pension plan's fiduciary net position. The net pension liability calculation is dependent on critical long-term variables, including estimated average life expectancies, earnings on investments, cost of living adjustments and others. While these estimates use the best information available, unknowable future events require adjusting this estimate annually.

Ohio Revised Code limits the City's obligation for this liability to annually required payments. The City cannot control benefit terms or the manner in which pensions are financed; however, the City does receive the benefit of employees' services in exchange for compensation including pension.

GASB 68 assumes the liability is solely the obligation of the employer, because (1) they benefit from employee services; and (2) State statute requires all funding to come from these employers. All contributions to date have come solely from these employers (which also includes costs paid in the form of withholdings from employees). State statute requires the pension plans to amortize unfunded liabilities within 30 years. If the amortization period exceeds 30 years, each pension plan's board must propose corrective action to the State legislature. Any resulting legislative change to benefits or funding could significantly affect the net pension liability. Resulting adjustments to the net pension liability would be effective when the changes are legally enforceable.

The proportionate share of each plan's unfunded benefits is presented as a long-term *net pension liability* on the accrual basis of accounting. Any liability for the contractually-required pension contribution outstanding at the end of the year is included in *intergovernmental payable* on both the accrual and modified accrual bases of accounting.

B. Plan Description – Ohio Public Employees Retirement System (OPERS)

Plan Description - City employees participate in the Ohio Public Employees Retirement System (OPERS). OPERS administers three separate pension plans. The traditional pension plan is a cost-sharing, multiple-employer defined benefit pension plan. The member-directed plan is a defined contribution plan and the combined plan is a cost-sharing, multiple-employer defined benefit pension plan with defined contribution features. While members (e.g. City employees) may elect the member-directed plan and the combined plan, substantially all employee members are in OPERS' traditional plan; therefore, the following disclosure focuses on the traditional pension plan.

City of Brook Park, Ohio

Notes to the Basic Financial Statements (continued)

For The Year Ended December 31, 2017

Note 11: Defined Benefit Pension Plans (Continued)

B. Plan Description – Ohio Public Employees Retirement System (OPERS) (Continued)

OPERS provides retirement, disability, survivor and death benefits, and annual cost of living adjustments to members of the traditional plan. City to establish and amend benefits is provided by Chapter 145 of the Ohio Revised Code. OPERS issues a stand-alone financial report that includes financial statements, required supplementary information and detailed information about OPERS’ fiduciary net position that may be obtained by visiting <https://www.opers.org/financial/reports.shtml>, by writing to the Ohio Public Employees Retirement System, 277 East Town Street, Columbus, Ohio 43215-4642, or by calling 800-222-7377.

Senate Bill (SB) 343 was enacted into law with an effective date of January 7, 2013. In the legislation, members were categorized into three groups with varying provisions of the law applicable to each group. The following table provides age and service requirements for retirement and the retirement formula applied to final average salary (FAS) for the three member groups under the traditional plan as per the reduced benefits adopted by SB 343 (see OPERS’ CAFR referenced above for additional information):

Group A Eligible to retire prior to January 7, 2013 or five years after January 7, 2013	Group B 20 years of service credit prior to January 7, 2013 or eligible to retire ten years after January 7, 2013	Group C Members not in other Groups and members hired on or after January 7, 2013
State and Local	State and Local	State and Local
Age and Service Requirements: Age 60 with 60 months of service credit or Age 55 with 25 years of service credit	Age and Service Requirements: Age 60 with 60 months of service credit or Age 55 with 25 years of service credit	Age and Service Requirements: Age 62 with 5 years of service credit or Age 57 with 25 years of service credit
Formula: 2.2% of FAS multiplied by years of service for the first 30 years and 2.5% for service years in excess of 30	Formula: 2.2% of FAS multiplied by years of service for the first 30 years and 2.5% for service years in excess of 30	Formula: 2.2% of FAS multiplied by years of service for the first 35 years and 2.5% for service years in excess of 35

Final average Salary (FAS) represents the average of the three highest years of earnings over a member’s career for Groups A and B. Group C is based on the average of the five highest years of earnings over a member’s career.

Members who retire before meeting the age and years of service credit requirement for unreduced benefits receive a percentage reduction in the benefit amount.

When a benefit recipient has received benefits for 12 months, an annual cost of living adjustment (COLA) is provided. This COLA is calculated on the base retirement benefit at the date of retirement and is not compounded. For those retiring prior to January 7, 2013, the COLA will continue to be a 3 percent simple annual COLA. For those retiring subsequent to January 7, 2013, beginning in calendar year 2019, the COLA will be based on the average percentage increase in the Consumer Price Index, capped at 3 percent.

Funding Policy - The Ohio Revised Code (ORC) provides statutory City for member and employer contributions as follows:

City of Brook Park, Ohio

Notes to the Basic Financial Statements (continued)

For The Year Ended December 31, 2017

Note 11: Defined Benefit Pension Plans (Continued)

B. Plan Description – Ohio Public Employees Retirement System (OPERS) (Continued)

	<u>State and Local</u>
2017 Statutory Maximum Contribution Rates	
Employer	14.0 %
Employee	10.0 %
2017 Actual Contribution Rates	
Employer:	
Pension	13.0 %
Post-Employment Health Care Benefits	<u>1.0</u>
Total Employer	<u>14.0 %</u>
Employee	<u>10.0 %</u>

Employer contribution rates are actuarially determined and are expressed as a percentage of covered payroll. The City's contractually required contributions was \$710,650 for fiscal year ending December 31, 2017.

C. Plan Description – Ohio Police & Fire Pension Fund (OP&F)

Plan Description - City full-time police and firefighters participate in Ohio Police and Fire Pension Fund (OP&F), a cost-sharing, multiple-employer defined benefit pension plan administered by OP&F. OP&F provides retirement and disability pension benefits, annual cost-of-living adjustments, and death benefits to plan members and beneficiaries. Benefit provisions are established by the Ohio State Legislature and are codified in Chapter 742 of the Ohio Revised Code. OP&F issues a publicly available financial report that includes financial information and required supplementary information and detailed information about OP&F fiduciary net position. The report may be obtained by visiting the OP&F website at www.op-f.org or by writing to the Ohio Police and Fire Pension Fund, 140 East Town Street, Columbus, Ohio 43215-5164.

Upon attaining a qualifying age with sufficient years of service, a member of OP&F may retire and receive a lifetime monthly pension. OP&F offers four types of service retirement: normal, service commuted, age/service commuted and actuarially reduced. Each type has different eligibility guidelines and is calculated using the member's average annual salary. The following discussion of the pension formula relates to normal service retirement.

For members hired after July 1, 2013, the minimum retirement age is 52 for normal service retirement with at least 25 years of service credit. For members hired on or before July 1, 2013, the minimum retirement age is 48 for normal service retirement with at least 25 years of service credit.

City of Brook Park, Ohio

Notes to the Basic Financial Statements (continued)

For The Year Ended December 31, 2017

Note 11: Defined Benefit Pension Plans (Continued)

C. Plan Description – Ohio Police & Fire Pension Fund (OP&F) (Continued)

The annual pension benefit for normal service retirement is equal to a percentage of the allowable average annual salary. The percentage equals 2.5 percent for each of the first 20 years of service credit, 2.0 percent for each of the next five years of service credit and 1.5 percent for each year of service credit in excess of 25 years. The maximum pension of 72 percent of the allowable average annual salary is paid after 33 years of service credit.

Under normal service retirement, retired members who are at least 55 years old and have been receiving OP&F benefits for at least one year may be eligible for a cost-of-living allowance adjustment. The age 55 provision for receiving a COLA does not apply to those who are receiving a permanent and total disability benefit and statutory survivors.

Members retiring under normal service retirement, with less than 15 years of service credit on July 1, 2013, will receive a COLA equal to either three percent or the percent increase, if any, in the consumer price index (CPI) over the 12-month period ending on September 30 of the immediately preceding year, whichever is less. The COLA amount for members with at least 15 years of service credit as of July 1, 2013 is equal to three percent of their base pension or disability benefit.

Funding Policy - The Ohio Revised Code (ORC) provides statutory authority for member and employer contributions as follows:

	<u>Police</u>	<u>Firefighters</u>
2017 Statutory Maximum Contribution Rates		
Employer	19.50 %	24.00 %
Employee	12.25 %	12.25 %
2017 Actual Contribution Rates		
Employer:		
Pension	19.00 %	23.50 %
Post-employment Health Care Benefits	0.50	0.50
Total Employer	<u>19.50 %</u>	<u>24.00 %</u>
Employee	12.25 %	12.25 %

Employer contribution rates are expressed as a percentage of covered payroll. The City's contractually required contribution to OP&F was \$1,319,709 for 2017.

City of Brook Park, Ohio

Notes to the Basic Financial Statements (continued)

For The Year Ended December 31, 2017

Note 11: Defined Benefit Pension Plans (Continued)

D. Pension Liabilities, Pension Assets, Pension Expense, and Deferred Outflows of Resources and Deferred Inflows of Resources Related to Pensions

The net pension liability for OPERS was measured as of December 31, 2016, and the total pension liability used to calculate the net pension liability was determined by an actuarial valuation as of that date. OP&F's total pension liability was measured as of December 31, 2016 and was determined by rolling forward the total pension liability as of January 1, 2016, to December 31, 2016. The City's proportion of the net pension liability was based on the City's share of contributions to the pension plan relative to the contributions of all participating entities. Following is information related to the proportionate share and pension expense:

	OPERS Traditional Pension Plan	OPERS Combined Pension Plan	OP&F Police	OP&F Fire	Total
Proportion of the Net Pension Liability/Asset Prior Measurement Date	0.040125%	0.027150%	0.128843%	0.140389%	
Proportion of the Net Pension Liability/Asset Current Measurement Date	<u>0.041502%</u>	<u>0.020787%</u>	<u>0.128020%</u>	<u>0.142665%</u>	
Change in Proportionate Share	<u>0.001377%</u>	<u>-0.006363%</u>	<u>-0.000823%</u>	<u>0.002276%</u>	
Proportionate Share of the Net Pension Liability/(Asset)	\$ 9,424,398	\$ (11,569)	\$ 8,108,677	\$ 9,036,258	\$ 26,557,764
Pension Expense	\$ 1,763,094	\$ 8,547	\$ 873,092	\$ 1,048,961	\$ 3,693,694

At December 31, 2017, the City reported deferred outflows of resources and deferred inflows of resources related to pensions from the following sources:

	OPERS Traditional Pension Plan	OPERS Combined Pension Plan	OP&F Police	OP&F Fire	Total
Deferred Outflows of Resources					
Net difference between projected and actual earnings on pension plan investments	\$1,403,510	\$2,824	\$788,533	\$878,736	\$3,073,603
Changes of assumptions	1,494,824	2,820			1,497,644
Differences between expected and actual experience	12,774	-	2,294	2,557	17,625
Changes in proportion and differences between City contributions and proportionate share of contributions	116,943	2,690	-	102,834	222,467
City contributions subsequent to the measurement date	<u>700,502</u>	<u>10,148</u>	<u>619,892</u>	<u>699,817</u>	<u>2,030,359</u>
Total Deferred Outflows of Resources	<u>\$3,728,553</u>	<u>\$18,482</u>	<u>\$1,410,719</u>	<u>\$1,683,944</u>	<u>\$6,841,698</u>
Deferred Inflows of Resources					
Differences between expected and actual experience	\$ 56,089	\$ 5,919	\$ 18,669	\$ 20,806	\$ 101,483
Changes in proportion and differences between City contributions and proportionate share of contributions	<u>340,266</u>	<u>493</u>	<u>\$549,566</u>	<u>\$386,259</u>	<u>1,276,584</u>
Total Deferred Inflows of Resources	<u>\$396,355</u>	<u>\$6,412</u>	<u>\$568,235</u>	<u>\$407,065</u>	<u>\$ 1,378,067</u>

City of Brook Park, Ohio

Notes to the Basic Financial Statements (continued)

For The Year Ended December 31, 2017

Note 11: Defined Benefit Pension Plans (Continued)

D. Pension Liabilities, Pension Assets, Pension Expense, and Deferred Outflows of Resources and Deferred Inflows of Resources Related to Pensions (Continued)

\$2,030,359 reported as deferred outflows of resources related to pension resulting from City's contributions subsequent to the measurement date will be recognized as a reduction of the net pension liability in the year ending December 31, 2018. Other amounts reported as deferred outflows of resources and deferred inflows of resources related to pension will be recognized in pension expense as follows:

Year Ending June 30:	OPERS	OPERS	OP&F	Police	OP&F Fire
	Traditional Pension Plan	Combined Pension Plan			
2018	\$942,216	\$812	\$169,658		\$261,444
2019	1,226,907	813	169,658		261,446
2020	503,715	691	98,199		181,810
2021	(41,142)	(308)	(183,319)		(131,912)
2022	-	(204)	(30,919)		2,203
Thereafter	-	118	(685)		2,071
Total	<u>2,631,696</u>	<u>1,922</u>	<u>222,592</u>		<u>577,062</u>

E. Actuarial Assumptions - OPERS

Actuarial valuations of an ongoing plan involve estimates of the values of reported amounts and assumptions about the probability of occurrence of events far into the future. Examples include assumptions about future employment, mortality, and cost trends. Actuarially determined amounts are subject to continual review or modification as actual results are compared with past expectations and new estimates are made about the future.

Projections of benefits for financial reporting purposes are based on the substantive plan (the plan as understood by the employers and plan members) and include the types of benefits provided at the time of each valuation. The total pension liability in the December 31, 2016, actuarial valuation was determined using the following actuarial assumptions, applied to all prior periods included in the measurement in accordance with the requirements of GASB 67. In 2016, the Board of Trustees' actuarial consultants conducted an experience study for the period 2011 through 2015, comparing assumptions to actual results. The experience study incorporates both a historical view and forward-looking projections to determine the appropriate set of assumptions to keep the plan on a path toward full funding. Information from this study led to changes in both demographic and economic assumptions, with the most notable being a reduction in the actuarially assumed rate of return from 8.0 percent down to 7.5 percent, for the defined benefit investments. Key methods and assumptions used in the latest actuarial valuation, reflecting experience study results, are presented on the following page:

City of Brook Park, Ohio

Notes to the Basic Financial Statements (continued)

For The Year Ended December 31, 2017

Note 11: Defined Benefit Pension Plans (Continued)

E. Actuarial Assumptions – OPERS (Continued)

Wage Inflation	3.25 percent
Future Salary Increases, including inflation COLA or Ad Hoc COLA	3.25 to 10.75 percent including wage inflation Pre 1/7/2013 retirees; 3 percent, simple Post 1/7/2013 retirees; 3 percent, simple through 2018, then 2.15 percent simple
Investment Rate of Return	7.5 percent
Actuarial Cost Method	Individual Entry Age

The total pension asset in the December 31, 2016, actuarial valuation was determined using the following actuarial assumptions, applied to all periods included in the measurement:

Wage Inflation	3.25 percent
Future Salary Increases, including inflation COLA or Ad Hoc COLA	3.25 to 8.25 percent including wage inflation Pre 1/7/2013 retirees; 3 percent, simple Post 1/7/2013 retirees; 3 percent, simple through 2018, then 2.15 percent simple
Investment Rate of Return	7.5 percent
Actuarial Cost Method	Individual Entry Age

Mortality rates were based on the RP-2014 Health Annuitant Mortality table. For males, Health Annuitant Mortality tables were used, adjusted for mortality improvement back to the observant period base of 2006 and then established the base year as 2015. For females, Health Annuitant Mortality tables were used, adjusted for mortality improvements back to the observation period base year of 2006 and then established the base year as 2010. The mortality rates used in evaluating disability allowances were based on the RP-2014 Disabled Mortality tables, adjusted for mortality improvement back to the observation base year of 2006 and then established the base year as 2015 for males and 2010 for females. Mortality rates for a particular calendar year for both healthy and disabled retiree mortality tables are determined by applying the MP-2015 mortality improvement scale to the above described tables.

The most recent experience study was completed for the five-year period ended December 31, 2015.

The long-term rate of return on defined benefit investment assets was determined using a building-block method in which best-estimate ranges of expected future real rates of return are developed for each major asset class. These ranges are combined to produce the long-term expected real rate of return by weighting the expected future real rates of return by the target asset allocation percentage, adjusted for inflation.

OPERS manages investments in four investment portfolios: the Defined Benefits portfolio, the 401(h) Health Care Trust portfolio, the 115 Health Care Trust portfolio and the Defined Contribution portfolio. The 401(h) Health Care Trust portfolio was closed as of June 30, 2016 and the net position transferred to the 115 Health Care Trust portfolio on July 1, 2016. The Defined Benefit portfolio includes the investment assets of the Traditional Pension Plan, the defined benefit component of the Combined Plan, the annuitized accounts of the Member-Directed Plan. The Defined Benefit portfolio historically included the assets of the Member-Directed retiree medical accounts funded through the VEBA Trust. However, the VEBA Trust was closed as of June 30, 2016. Within the Defined Benefit portfolio, contributions into the plans are all recorded at the same time, and benefit payments all occur on the first of the month.

City of Brook Park, Ohio

Notes to the Basic Financial Statements (continued)

For The Year Ended December 31, 2017

Note 11: Defined Benefit Pension Plans (Continued)

E. Actuarial Assumptions – OPERS (Continued)

Accordingly, the money-weighted rate of return is considered to be the same for all plans within the portfolio. The annual money weighted rate of return expressing investment performance, net of investments expenses and adjusted for the changing amounts actually invested, for the Defined Benefit portfolio is 8.3 percent for 2016.

The allocation of investment assets with the Defined Benefit portfolio is approved by the Board of Trustees as outlined in the annual investment plan. Plan assets are managed on a total return basis with a long-term objective of achieving and maintaining a fully funded status for the benefits provided through the defined benefit pension plans. The table below displays the Board-approved asset allocation policy for 2016 and the long-term expected real rates of return:

Asset Class	Target Allocation	Weighted Average Long-Term Expected Real Rate of Return (Arithmetic)
Fixed Income	23.00 %	2.75 %
Domestic Equities	20.70	6.34
Real Estate	10.00	4.75
Private Equity	10.00	8.97
International Equities	18.30	7.95
Other investments	18.00	4.92
Total	100.00 %	5.66 %

Discount Rate The discount rate used to measure the total pension liability was 7.5 percent, post-experience study results. The projection of cash flows used to determine the discount rate assumed that contributions from plan members and those of the contributing employers are made at the contractually required rates, as actuarially determined. Based on those assumptions, the pension plan's fiduciary net position was projected to be available to make all projected future benefits payments of current plan members. Therefore, the long-term expected rate of return on pension plan investments was applied to all periods of projected benefit payments to determine the total pension liability.

Sensitivity of the City's Proportionate Share of the Net Pension Liability to Changes in the Discount Rate

The following table presents the City's proportionate share of the net pension liability calculated using the current period discount rate assumption of 7.5 percent, as well as what the City's proportionate share of the net pension liability would be if it were calculated using a discount rate that is one-percentage-point lower (6.5 percent) or one-percentage-point higher (8.5 percent) than the current rate:

City's proportionate share of the net pension liability/(asset)	1% Decrease (6.50%)	Current Discount Rate (7.50%)	1% Increase (8.50%)
Traditional Pension Plan	\$14,397,874	9,424,398	\$5,279,884
Combined Plan	\$831	(11,569)	(\$21,203)

City of Brook Park, Ohio

Notes to the Basic Financial Statements (continued)

For The Year Ended December 31, 2017

Note 11: Defined Benefit Pension Plans (Continued)

F. Actuarial Assumptions – OP&F

OP&F's total pension liability as of December 31, 2016 is based on the results of an actuarial valuation date of January 1, 2016 and rolled-forward using generally accepted actuarial procedures. The total pension liability is determined by OP&F's actuaries in accordance with GASB Statement No. 67, as part of their annual valuation. Actuarial valuations of an ongoing plan involve estimates of reported amounts and assumptions about probability of occurrence of events far into the future. Examples include assumptions about future employment mortality, salary increases, disabilities, retirements and employment terminations. Actuarially determined amounts are subject to continual review and potential modifications, as actual results are compared with past expectations and new estimates are made about the future.

Key methods and assumptions used in calculating the total pension liability in the latest actuarial valuation, prepared as of January 1, 2016, are presented below:

Valuation Date	January 1, 2016
Actuarial Cost Method	Entry Age Normal
Investment Rate of Return	8.25 percent
Projected Salary Increases	4.25 percent to 11 percent
Payroll Increases	3.75 percent
Inflation Assumptions	3.25 percent
Cost of Living Adjustments	2.60 percent and 3.00 percent Simple

Rates of death are based on the RP2000 Combined Table, age-adjusted as follows. For active members, set back six years. For disability retirements, set forward five years for police and three years for firefighters. For service retirements, set back zero years for police and two years for firefighters. For beneficiaries, set back zero years. The rates are applied on a fully generational basis, with a base year of 2009, using mortality improvement Scale AA.

The most recent experience study was completed January 1, 2012.

The long-term expected rate of return on pension plan investments was determined using a building-block approach and assumes a time horizon, as defined in the Statement of Investment Policy. A forecasted rate of inflation serves as the baseline for the return expectation. Various real return premiums over the baseline inflation rate have been established for each asset class. The long-term expected nominal rate of return has been determined by calculating a weighted averaged of the expected real return premiums for each asset class, adding the projected inflation rate and adding the expected return from rebalancing uncorrelated asset classes. Best estimates of the long-term expected geometric real rates of return for each major asset class included in OP&F's target asset allocation as of December 31, 2016 are summarized on the next page:

City of Brook Park, Ohio

Notes to the Basic Financial Statements (continued)

For The Year Ended December 31, 2017

Note 11: Defined Benefit Pension Plans (Continued)

F. Actuarial Assumptions – OP&F (Continued)

Asset Class	Target Allocation	10 year Expected Real Rate of Return **	30 year Expected Real Rate of Return **
Cash and Cash Equivalents	- %		
Domestic Equity	16.00	4.46 %	5.21 %
Non-US Equity	16.00	4.66	5.40
Core Fixed Income *	20.00	1.67	2.37
Global Inflation Protected *	20.00	0.49	2.33
High Yield	15.00	3.33	4.48
Real Estate	12.00	4.71	5.65
Private Markets	8.00	7.31	7.99
Timber	5.00	6.87	6.87
Master Limited Partnerships	8.00	6.92	7.36
 Total	 <u>120.00 %</u>		

* levered 2x

** numbers are net of expected inflation

OP&F's Board of Trustees has incorporated the "risk parity" concept into OP&F's asset liability valuation with the goal of reducing equity risk exposure, which reduces overall Total Portfolio risk without sacrificing return, and creating a more risk-balanced portfolio based on their relationship between asset classes and economic environments. From the notional portfolio perspective above, the Total Portfolio may be levered up to 1.2 times due to the application of leverage in certain fixed income asset classes.

Discount Rate The total pension liability was calculated using the discount rate of 8.25 percent. The projection of cash flows used to determine the discount rate assumed the contributions from employers and from the members would be computed based on contribution requirements as stipulated by State statute. Projected inflows from investment earning were calculated using the longer-term assumed investment rate of return 8.25 percent. Based on those assumptions, the plan's fiduciary net position was projected to be available to make all future benefit payments of current plan members. Therefore, a long-term expected rate of return on pension plan investments was applied to all periods of projected benefits to determine the total pension liability.

Sensitivity of the City's Proportionate Share of the Net Pension Liability to Changes in the Discount Rate

Net pension liability is sensitive to changes in the discount rate, and to illustrate the potential impact the following table presents the net pension liability calculated using the discount rate of 8.25 percent, as well as what the net pension liability would be if it were calculated using a discount rate that is one percentage point lower (7.25 percent), or one percentage point higher (9.25 percent) than the current rate.

	1% Decrease (7.25%)	Current Discount Rate (8.25%)	1% Increase (9.25%)
City's proportionate share of the net pension liability	\$ 22,834,997	\$ 17,144,935	\$ 12,322,496

City of Brook Park, Ohio

Notes to the Basic Financial Statements (continued)

For The Year Ended December 31, 2017

Note 11: Defined Benefit Pension Plans (Continued)

F. Actuarial Assumptions – OP&F (Continued)

Changes Between Measurement Date and Report Date In October 2017, the OP&F Board adopted certain assumption changes which will impact their annual actuarial valuation prepared as of January 1, 2017. The most significant change is a reduction in the discount rate from 8.25 percent to 8 percent. Although the exact amount of these changes is not known, it has the potential to impact the City's net pension liability.

Note 12: Post-Employment Benefits

A. Ohio Public Employees Retirement System

Plan Description - The Ohio Public Employees Retirement System (OPERS) administers three separate pension plans; the Traditional Pension Plan is a cost-sharing, multiple-employer defined benefit pension plan; the Member-Directed Plan is a defined contribution plan; and the Combined Plan is a cost-sharing, multiple-employer defined benefit pension plan that has elements of both a defined benefit and a defined contribution plan.

OPERS maintains a cost-sharing, multiple-employer defined benefit post-employment health care trust, which funds multiple health care plans including medical coverage, prescription drug coverage and deposits to a Health Reimbursement Arrangement to qualifying benefit recipients of both the Traditional Pension and the Combined plans. The trust is also used to fund health care for Member-Directed Plan participants, in the form of a Retiree Medical Account (RMA). At retirement or refund, participants can be reimbursed for qualified medical expenses from their vested RMA balance.

In order to qualify for health care coverage, age-and-service retirees under the Traditional Pension and Combined plans must have 20 or more years of qualifying Ohio service credit. Health care coverage for disability benefit recipients and qualified survivor benefit recipients is available. The health care coverage provided by OPERS meets the definition of an Other Post Employment Benefit (OPEB) as described in GASB Statement 45. Please see the Plan Statement in the OPERS 2016 CAFR for details.

The Ohio Revised Code permits, but does not require, OPERS to provide health care to its eligible benefit recipients. Authority to establish and amend health care coverage is provided to the OPERS Board of Trustees (OPERS Board) in Chapter 145 of the Ohio Revised Code.

OPERS issues a stand-alone financial report. Interested parties may obtain a copy by visiting <https://www.opers.org/financial/reports.shtml#CAFR>, by writing to OPERS, 277 East Town Street, Columbus, OH 43215-4642, or by calling 614-222-5601 or 800-222-7377.

Funding Policy - The Ohio Revised Code provides the statutory authority requiring public employers to fund post-retirement health care through their contributions to OPERS. A portion of each employer's contribution to OPERS is set aside for the funding of post-retirement health care coverage. Employer contribution rates are expressed as a percentage of the earnable salary of active members. In 2017, State and Local employers contributed at a rate of 14.00 percent of earnable salary and Public Safety and Law Enforcement employers contributed at 18.10 percent. These are the maximum employer contribution rates permitted by the Ohio Revised Code. Active member contributions do not fund health care.

City of Brook Park, Ohio

Notes to the Basic Financial Statements (continued)

For The Year Ended December 31, 2017

Note 12: Post-Employment Benefits (continued)

A. Ohio Public Employees Retirement System (continued)

Each year, the OPERS Board of Trustees determines the portion of the employer contribution rate that will be set aside to fund health care plans. The portion of employer contributions allocated to health care for members in the Traditional Pension Plan and Combined Plan was 1.00 percent during calendar year 2017. As recommended by the OPERS' actuary, the portion of employer contributions allocated to health care beginning January 1, 2018 decreased to 0.00 percent for both plans. The OPERS Board is also authorized to establish rules for the retiree or their surviving beneficiaries to pay a portion of the health care benefits provided. Payment amounts vary depending on the number of covered dependents and the coverage selected. The employer contribution as a percentage of covered payroll deposited for Member-Directed Plan participants for 2017 was 4.0 percent. The City's actual employer contributions for December 31, 2017, 2016 and 2015 which were used to fund post-employment benefits were \$54,726, \$108,910, and \$102,020, respectively; 100 percent has been contributed for 2017, 2016 and 2015.

B. Ohio Police and Fire Pension Fund

Plan Description - The City contributes to the Ohio Police and Fire Pension Fund (OP&F) sponsored health care program, a cost-sharing multiple-employer defined benefit post-employment health care plan administered by OP&F. OP&F provides health care benefits including coverage for medical, prescription drugs, dental, vision, Medicare Part B Premium and long-term care to retirees, qualifying benefit recipients and their eligible dependents.

OP&F provides access to post-retirement health care coverage for any person who receives or is eligible to receive a monthly service, disability, or statutory survivor benefit or is a spouse or eligible dependent child of such person. The health care coverage provided by OP&F meets the definition of an Other Post-Employment Benefit (OPEB) as described in GASB Statement No. 45.

The Ohio Revised Code allows, but does not mandate OP&F to provide OPEB benefits. Authority for the OP&F Board of Trustees to provide health care coverage to eligible participants and to establish and amend benefits is codified in Chapter 742 of the Ohio Revised Code.

OP&F issues a publicly available financial report that includes financial information and required supplementary information for the Plan. That report may be obtained by writing to OP&F, 140 East Town Street, Columbus, OH 43215-5164. That report is also available on OP&F's website at www.op-f.org.

Funding Policy - The Ohio Revised Code provides for contribution requirements of the participating employers and of plan members to the OP&F (defined benefit pension plan). Participating employers are required to contribute to the pension plan at rates expressed as percentages of the payroll of active pension plan members, currently, 19.50 percent and 24.00 percent of covered payroll for police and fire employers, respectively. The Ohio Revised Code states that the employer contribution may not exceed 19.50 percent of covered payroll for police employer units and 24.00 percent of covered payroll for fire employer units. Active members do not make contributions to the OPEB plan.

City of Brook Park, Ohio

Notes to the Basic Financial Statements (continued)

For The Year Ended December 31, 2017

Note 12: Post-Employment Benefits (continued)

B. Ohio Police and Fire Pension Fund (continued)

OP&F maintains funds for health care in two separate accounts. One for health care benefits under an IRS Code Section 115 trust and one for Medicare Part B reimbursements administered as an Internal Revenue Code 401(h) account, both of which are within the defined benefit pension plan, under the authority granted by the Ohio Revised Code to the OP&F Board of Trustees.

The Board of Trustees is authorized to allocate a portion of the total employer contributions made into the pension plan to the Section 115 Trust and the Section 401(h) account as the employer contribution for retiree health care benefits. The portion of employer contributions allocated to health care was 0.50 percent of covered payroll from January 1, 2017 thru December 31, 2017. The amount of employer contributions allocated to the health care plan each year is subject to the Trustees' primary responsibility to ensure that pension benefits are adequately funded and is limited by the provisions of the Sections 115 and 401(h).

The OP&F Board of Trustees also is authorized to establish requirements for contributions to the health care plan by retirees and their eligible dependents, or their surviving beneficiaries. Payment amounts vary depending on the number of covered dependents and the coverage selected.

The City's contributions to OP&F which were allocated to fund post-employment health care benefits for police and firefighters were \$16,251 and \$14,740 for the year ended December 31, 2017, \$15,292 and \$13,846 for the year ended December 31, 2016, and \$16,737 and \$14,030 for the year ended December 31, 2015, respectively. The full amount has been contributed for 2017, 2016 and 2015.

Note 13: Other Postemployment Benefits

Plan Description

The City provides post-employment health care and life insurance benefits (OPEB) for retired employees through a single-employer defined benefit plan. The benefits, benefit levels, employee contributions and employer contributions are governed by the City and can be amended by the City through its union contracts. The activity of the plan is reported in the City's General Fund as part of the general government expenditure function.

Benefits Provided

The City provides post-employment health care and life insurance benefits to its retirees. In order to be eligible for the benefit, a retired employee or surviving spouse must be at least age 65 plus 10 consecutive years of service prior to retirement. In addition, a retired employee/surviving spouse must be enrolled in Medicare Part B to be eligible for benefit.

Post-employment benefits include reimbursement of costs associated with health care coverage up to \$1,200 per year and a life insurance benefit of \$5,000 which the City provides the premium payment. Dependents of eligible retirees will continue to receive the post-employment benefits at the time of the retiree's death.

As of January 1, 2017, the City had 274 participants. Of that number, 136 were active employees and 138 were retirees and dependents that were currently receiving the post-employment benefits mentioned above.

City of Brook Park, Ohio

Notes to the Basic Financial Statements (continued)

For The Year Ended December 31, 2017

Note 13: Other Postemployment Benefits (Continued)

Funding Policy

The City's annual contributions to the plan are negotiated through the union contracts of the City. For the fiscal year ended December 31, 2017, the City contributed \$99,516 to the plan. The plan requires no matching contributions from the employees during their period of employment.

Annual OPEB Costs and Net OPEB Obligation

The City's latest actuarial valuation performed for the plan was as of December 31, 2015 (the latest information available) to determine the funded status of the plan as of that date as well as the employer's annual required contribution (ARC) for the fiscal year ended December 31, 2017. For 2017, the City's annual OPEB cost (expense) of \$261,635 was more than the actual employer contribution for the fiscal year and the net OPEB amount has been recorded as a liability on the government-wide financial statements. The City's annual OPEB cost, the percentage of annual OPEB cost contributed to the plan and the net OPEB obligation for 2017, 2016 and 2015 are as follows:

<u>Fiscal Year Ended</u>	<u>Annual Required Contribution</u>	<u>Interest on Net OPEB Obligation</u>	<u>Adjustment to the ARC</u>	<u>Annual OPEB Cost</u>	<u>Employer Contribution</u>	<u>% of Annual OPEB Cost Contributed</u>	<u>Change in Net OPEB Obligation</u>	<u>Net OPEB Obligation (Asset) Balance</u>
December 31, 2015	268,256	(5,996)	(19,953)	242,307	342,461	141.33%	(100,154)	(240,388)
December 31, 2016	268,256	(5,996)	(10,289)	251,971	118,212	46.91%	133,759	(106,629)
December 31, 2017	268,256	(5,996)	(625)	261,635	99,516	38.04%	162,119	55,490

Funded Status and Funding Progress

The funded status of the plan as of December 31, 2015 (the latest information available), was as follows:

	<u>2015</u>	<u>2013</u>	<u>2012</u>
Actuarial Accrued Liability (AAL)	\$ 4,064,370	\$ 3,980,994	\$ 4,147,692
Unfunded Actuarial Accrued Liability (UAAL)	\$ 4,064,370	\$ 3,980,994	\$ 4,147,692
Funded Ratio (Actuarial Value of Plan Assets/AAL)	0.00%	0.00%	0.00%

Actuarial valuations of an ongoing plan involve estimates of the value of reported amounts and assumptions about the probability of occurrence of events far into the future. Examples include assumptions about future employment, mortality and the healthcare cost trend. Amounts determined regarding the funded status of the plan and the ARCs of the employer are subject to continual revision as actual results are compared with past expectations and new estimates are made about the future.

Actuarial Methods and Assumptions

Projections of benefits for financial reporting purposes are based on the substantive plan (the plan as understood by the employer and plan members) and include the types of benefits provided at the time of each valuation and the historical pattern of sharing of benefit costs between the employer and plan members to that point. The actuarial methods and assumptions used include techniques that are designed to reduce short-term volatility in actuarial accrued liabilities and the actuarial value of assets, consistent with long-term perspective of the calculations.

City of Brook Park, Ohio

Notes to the Basic Financial Statements (continued)

For The Year Ended December 31, 2017

Note 13: Other Postemployment Benefits (continued)

In the December 31, 2015 actuarial valuation, the projected unit credit cost method was used. The actuarial assumptions include a discount rate (interest rate) of 4.00 percent and a healthcare cost trend rate (which is the anticipated rate of future increases in health care costs due to inflation) of 3.00 percent which applies to uncapped reimbursements only and equals approximate historical increase in uncapped reimbursements. The actuarial value of assets was zero as a result of the City's pay-as-you-go funding of the plan and premiums are paid when due. The plan's unfunded actuarial accrued liability is being amortized as a level percentage of projected payrolls on a closed basis. The remaining amortization period at December 31, 2015, was 23 years.

Note 14: Risk Management

The City is exposed to various risks of loss related to torts; theft of, damage to, and destruction of assets; errors and omissions; injuries to employees and natural disasters. During the year, the City contracted with Wichert Insurance Services, Inc. to manage its insurance coverage. The City's insurance carrier for all coverages is Selective Insurance Co. of America. The coverage limits, on December 31, 2017, per occurrence for all types of coverage are as follows:

<u>Type of Coverage</u>	<u>Coverage</u>
Property:	
Blanket building and contents	\$ 51,022,649
Business income and extra expense	Actual Loss Sustained-12 mos.
General liability:	
Commercial general liability, which includes:	2,000,000
Employee benefits	1,000,000
Employers liability (Ohio stop gap)	1,000,000
Automotive liability	1,000,000
Excess liability:	
Umbrella, which includes:	10,000,000
All underlying liabilities	
Public officials and law enforcement	
Other types of coverages:	
Contractors equipment	1,190,325
EDP equipment	346,585
Employee dishonesty	1,000,000
Valuable papers	100,000
Accounts receivable	100,000
Law enforcement	1,000,000
Public Officials	1,000,000
Flood	Each Occurrence 5,000,000 Aggregate 10,000,000
Earthquake	Each Occurrence 5,000,000 Aggregate 10,000,000

There were no reductions in insurance coverage from the previous year, nor have settlements exceeded insurance coverage in any of the prior three fiscal years.

City of Brook Park, Ohio

Notes to the Basic Financial Statements (continued)

For The Year Ended December 31, 2017

Note 14: Risk Management (continued)

During 2017, the City switched from self-funded program for health insurance to a shared-funding plan provided by a commercial insurance carrier. The City will pay up to a predetermined amount towards each employee's health care costs after employee's health care costs after employees meet their deductible. Once this "funding corridor" has been met, the insurance company will pay the employee's remaining annual health care costs.

All claims were still paid out of the Internal Service Fund, which will be closed out during 2018. The Internal Service fund is still being maintained until City is certain that all prior claims have been paid out as there is uncertainty as to exactly when claims will be processed. As of December 31, 2017, there are no known claims payable to the City. The changes in fund's claims liability amount for the last three years follow:

	Beginning of Year Liability	Current Year Claims	Claim Payments	Balance at Year End
2015	\$ 175,835	\$ 2,003,922	\$ (2,021,882)	\$ 157,875
2016	157,875	1,484,467	(1,543,327)	99,015
2017	99,015	13,168	(112,183)	-

The State of Ohio provides workers' compensation coverage. The City pays the State Workers' Compensation System a premium based on a rate per \$100 of salaries. This rate is calculated based on accident history and administrative costs.

Note 15: Construction and Other Significant Commitments

At December 31, 2017, the City's significant contractual construction commitments consisted of:

Project	Amount	Paid	on Contract
Snow Rd Resurfacing	\$ 3,419,380	\$ 3,185,017	\$ 234,363
Smith Rd Sanitary Sewer Impr.	1,789,704	1,706,901	82,803
Fry Rd Reconstruction	1,613,747	1,448,932	164,815
Community Center Renovation	4,979,736	2,731,230	2,248,506
Total	\$ 11,802,567	\$ 9,072,080	\$ 2,730,487

The City utilizes encumbrance accounting as part of its budgetary controls. Encumbrances outstanding at year-end are components of fund balance for subsequent year expenditures and may be reported as part of restricted, committed, or assigned classifications of fund balance. As of December 31, 2017, the City's commitments for encumbrances in the governmental funds were as follows:

	Encumbrances Outstanding
Major Funds:	
General	\$ 270,439
Capital Improvements	5,256,594
Nonmajor Funds:	
Special Revenue Funds	538,995
Total	\$ 6,066,028

City of Brook Park, Ohio

Notes to the Basic Financial Statements (continued)

For The Year Ended December 31, 2017

Note 16: Interfund Transfers

Interfund transfers for the year ended December 31, 2017, consisted of the following:

Transfer To	Transfer From		Total
	General Fund	Capital Improvements Fund	
Capital Improvements Fund	\$ 3,189,000	\$ -	\$ 3,189,000
Other Governmental Funds	1,385,000	653,068	2,038,068
Total	<u>\$ 4,574,000</u>	<u>\$ 653,068</u>	<u>\$ 5,227,068</u>

Transfers are used to move revenues from the fund that statute or budget requires to collect them to the fund that statute or budget requires to expend them and unrestricted revenues collected in the general fund to finance various programs accounted for in other funds in accordance with budgetary authorizations; to segregate money for anticipated capital projects; to provide additional resources for current operations or debt service; and to return money to the fund from which it was originally provided once a project is completed.

Note 17: Contingencies/Pending Litigation

A. Grants

The City received financial assistance from Federal and State agencies in the form of grants. The disbursement of funds received under these programs generally requires compliance with the terms and conditions specified in the grant agreements and are subject to audit by the grantor agencies. Any disallowed claims resulting from such audits could become a liability of the General Fund or other applicable funds. However, in the opinion of management, any such disallowed claims will not have a material adverse effect on the overall financial position of the City at December 31, 2017.

B. Litigation

There are claims and lawsuits that are pending against the City. The amount of the liability from these claims and lawsuits, if any, cannot be reasonably estimated at this time. However, in the opinion of management, any such claims and lawsuits will not have a material adverse effect on the overall financial position of the City at December 31, 2017.

City of Brook Park, Ohio

Notes to the Basic Financial Statements (continued)

For The Year Ended December 31, 2017

Note 18: Fund Balances

Fund balance is classified as nonspendable, restricted, committed, assigned and/or unassigned based primarily on the extent to which the City is bound to observe constraints imposed upon the use of the resources in the governmental funds. The constraints placed on fund balance for the major governmental funds and all other governmental funds are presented below:

Fund Balances	General Fund	Capital Improvements Fund	Other Governmental Funds	Total
<i>Nonspendable</i>				
Prepaid Items	\$ 148,298	\$ -	\$ 392	\$ 148,690
Materials and Supplies Inventory	87,820	-	-	87,820
Total Nonspendable	236,118	-	392	236,510
<i>Restricted for</i>				
Police Pension	-	-	31,585	31,585
Fire Pension	-	-	44,521	44,521
Other Law Enforcement	-	-	427,051	427,051
Streets and Highways	-	-	1,261,349	1,261,349
Southwest General Hospital	-	-	25	25
FEMA	-	-	54,663	54,663
CDBG	-	-	36,582	36,582
Debt Service	-	-	790,591	790,591
Capital Improvements	-	214,400	-	214,400
Community Center Improvemnet	-	2,248,506	-	2,248,506
W. 150th Sewer Improvements Phase	-	180,823	-	180,823
Snow Rd. Resurfacing	-	17,108	-	17,108
Total Restricted	-	2,660,837	2,646,367	5,307,204
<i>Committed to</i>				
Income Tax Allocation - Capital	-	2,159,263	-	2,159,263
Admissions Tax	547,773	-	-	547,773
Hotel and Motel Tax	513,221	-	-	513,221
Property Insurance	1,162,108	-	-	1,162,108
Retiree Accrued Benefits	28,137	-	-	28,137
Economic Development	-	-	250,866	250,866
Brook Park Road Corridor	-	-	57,835	57,835
Special Recreation	-	-	452,474	452,474
Ditch Cleaning Program	-	224,069	-	224,069
Sound Insulation Program	-	383,191	-	383,191
Street Programs	-	924,829	-	924,829
Total Committed	2,251,239	3,691,352	761,175	6,703,766
<i>Assigned to</i>				
Fiscal Year 2018 Appropriations	168,743	-	-	168,743
Park Concessions	10,756	-	-	10,756
Debt Service	-	-	1,105,049	1,105,049
Purchases on Order	222,593	-	-	222,593
Other	2,550	-	-	2,550
Total Assigned	404,642	-	1,105,049	1,509,691
<i>Unassigned (Deficit)</i>	6,028,519	-	-	6,028,519
Total Fund Balances	\$ 8,920,518	\$ 6,352,189	\$ 4,512,983	\$ 19,785,690

City of Brook Park, Ohio

Notes to the Basic Financial Statements (continued)

For The Year Ended December 31, 2017

Note 19: Tax Abatement Disclosure

The City of Brook Park provides tax incentive programs through Ohio Revised Code Chapter 3735.65-70 and/or Chapter 5709 (Community Re-Investment Act (CRA)) and through a payroll tax rebate program. The city established its CRA and has amended its program twice so that the entire city is covered by the CRA.

The CRA program provides the city with an important economic development tool to stimulate growth and redevelopment in its industrial, commercial and residential bases. The abate program provides a direct incentive property tax exemption for improvements to real estate within the City. Improvements to residential property (not containing more than 2 residential units) valued exceeding \$2,500 are available to receive a 10 year, 100% property tax abatement for the increase in assessed value resulting from the improvement. Remodeling in excess of \$5,000 to residential multi-family, commercial & industrial properties are eligible to receive a 12 year 100% abatement from the increase in assessed value resulting from the improvement. Likewise, construction of new commercial or industrial improvements (excluding properties primarily used in retail sales) are eligible for a 100%, fifteen (15) year abatement of real property taxes arising from the increase in assessed value resulting from the improvement. All CRA property tax abatements are reported to the State of Ohio on an annual basis.

Below is the information relevant to the disclosure of the CRA property tax abatement program for the year ended December 31, 2017:

Property	Date Certified	Project Type	Project Invoice	Value Subject to Exemption	Number of Jobs
Horchy	1/13/2014	Residential	\$ 72,100	all	n/a
Kuharik	11/26/2016	Residential	38,315	all	n/a
Bogdan R.E.	10/21/2015	Commercial	1,750,000	all	17
Lakeview Motor	7/24/2015	Commercial	3,900,000	all	15
18301 Brookpark	8/1/2016	Commercial	2,300,000	all	15

In the past the city has offered an income tax rebate (up to 50% for a defined period (up to five (5) years)) to entities with established multimillion dollar payrolls who agree to maintain established and negotiated payrolls for a defined period of years (7 years or longer). Like rebates have been offered to businesses with multi-million dollar payrolls in order to keep the business from relocating out of city due to a competitive rebate offer or to entice a business to relocate to our City by matching an income tax rebate offered by a competitive jurisdiction. No income tax rebates have been authorized by the City in the past four (4) years.

City of Brook Park, Ohio

Required Supplementary Information

Schedule of the City's Proportionate Share of the Net Pension Liability

Ohio Public Employees Retirement System

Last Four Years (1)

Traditional Plan	2017	2016	2015	2014
City's Proportion of the Net Pension Liability	0.041502%	0.040125%	0.048064%	0.048064%
City's Proportionate Share of the Net Pension Liability	9,424,398	\$6,950,154	\$5,797,055	\$5,666,119
City's Covered-Employee Payroll	\$5,364,108	\$4,993,992	\$5,912,167	\$6,018,854
City's Proportionate Share of the Net Pension Liability as a Percentage of its Covered Employee Payroll	175.69%	139.17%	98.05%	94.14%
Plan Fiduciary Net Position as a Percentage of the Total Pension Liability	77.25%	81.08%	86.45%	86.36%
Combined Plan	2017	2016	2015	2014
City's Proportion of the Net Pension (Asset)	0.020787%	0.027150%	0.024994%	0.024994%
City's Proportionate Share of the Net Pension (Asset)	(\$11,569)	(\$13,212)	(\$9,623)	(\$2,623)
City's Covered-Employee Payroll	\$80,917	\$98,792	\$92,050	\$106,362
City's Proportionate Share of the Net Pension (Asset) as a Percentage of its Covered Employee Payroll	14.30%	13.37%	10.45%	2.47%
Plan Fiduciary Net Position as a Percentage of the Total Pension Liability	116.55%	116.90%	114.83%	104.33%

(1) Information prior to 2014 is not available. Schedule is intended to show information for 10 years. Additional years be displayed as they become available.

Amounts presented as of the City's measurement date which is the prior year end.

City of Brook Park, Ohio

Requires Supplementary Information

Schedule of the City's Proportionate Share of the Net Pension Liability

Ohio Police and Fire Pension Fund

Last Four Years (1)

Police	2017	2016	2015	2014
City's Proportion of the Net Pension Liability	0.128020%	0.1288433%	0.1437298%	0.1437298%
City's Proportionate Share of the Net Pension Liability	8,108,677	\$8,288,580	\$7,445,803	\$7,000,092
City's Covered-Employee Payroll	\$3,076,132	\$2,916,400	\$3,354,032	\$3,061,875
City's Proportionate Share of the Net Pension Liability as a Percentage of its Covered Employee Payroll	263.60%	284.21%	222.00%	228.62%
Plan Fiduciary Net Position as a Percentage of the Total Pension Liability	68.36%	66.77%	71.71%	73.00%
Fire	2017	2016	2015	2014
City's Proportion of the Net Pension Liability	0.142665%	0.1403890%	0.1516112%	0.1516112%
City's Proportionate Share of the Net Pension Liability	9,036,258	\$9,031,323	\$7,854,092	\$7,383,941
City's Covered-Employee Payroll	\$2,786,979	\$2,569,609	\$2,812,226	\$2,830,504
City's Proportionate Share of the Net Pension Liability as a Percentage of its Covered Employee Payroll	324.23%	351.47%	279.28%	260.87%
Plan Fiduciary Net Position as a Percentage of the Total Pension Liability	68.36%	66.77%	71.71%	73.00%

(1) Information prior to 2014 is not available. Schedule is intended to show information for 10 years. Additional years will be displayed when they become available.

Amounts presented as of the City's measurement date which is the prior year end.

City of Brook Park, Ohio
 Required Supplementary Information
 Schedule of City Contributions
 Ohio Public Employees Retirement System
Last Five Years (1)

	<u>2017</u>	<u>2016</u>	<u>2015</u>	<u>2014</u>	<u>2013</u>
<u>Contractually Required Contributions</u>					
Traditional Plan	700,502	643,693	\$599,279	\$709,460	\$782,451
Combined Plan	<u>10,148</u>	<u>9,710</u>	<u>\$11,855</u>	<u>\$11,046</u>	<u>13,827</u>
Total Required Contributions	\$710,650	\$653,403	\$611,134	\$720,506	\$796,278
Contributions in Relation to the Contractually Required Contribution	<u>(\$710,650)</u>	<u>(\$653,403)</u>	<u>(\$611,134)</u>	<u>(\$720,506)</u>	<u>(\$796,278)</u>
Contribution Deficiency / (Excess)	<u>\$0</u>	<u>\$0</u>	<u>\$0</u>	<u>\$0</u>	<u>\$0</u>
City's Covered-Employee Payroll					
Traditional Plan	\$5,388,477	\$5,364,108	\$4,993,992	\$5,912,167	\$6,018,854
Combined Plan	\$78,062	\$80,917	\$98,792	\$92,050	\$106,362
<u>Pension Contributions as a Percentage of Covered-Employee Payroll</u>					
Traditional Plan	13.00%	12.00%	12.00%	12.00%	13.00%
Combined Plan	13.00%	12.00%	12.00%	12.00%	13.00%

(1) – Information prior to 2013 is not available. Schedule is intended to show information for 10 years. Additional years will be displayed as they become available.

City of Brook Park, Ohio
Required Supplementary Information
Schedule of City Contributions
Ohio Police and Fire Pension Fund
Last Ten Years

	<u>2017</u>	<u>2016</u>	<u>2015</u>	<u>2014</u>	<u>2013</u>	<u>2012</u>	<u>2011</u>	<u>2010</u>	<u>2009</u>	<u>2008</u>
<u>Contractually Required Contributions</u>										
Police	619,892	584,465	\$554,116	\$637,266	\$481,633	\$388,484	\$395,232	\$405,512	\$440,584	\$417,361
Fire	<u>699,817</u>	<u>654,940</u>	<u>\$603,858</u>	<u>\$660,873</u>	<u>\$572,611</u>	<u>\$517,304</u>	<u>\$538,686</u>	<u>\$538,555</u>	<u>\$561,992</u>	<u>\$559,327</u>
Total Required Contributions	\$1,319,709	\$1,239,405	\$1,157,974	\$1,298,139	\$1,054,244	\$905,788	\$933,918	\$944,067	\$1,002,576	\$976,688
Contributions in Relation to the Contractually Required Contribution	<u>(\$1,319,709)</u>	<u>(\$1,239,405)</u>	<u>(\$1,157,974)</u>	<u>(\$1,298,139)</u>	<u>(\$1,054,244)</u>	<u>(\$905,788)</u>	<u>(\$933,918)</u>	<u>(\$944,067)</u>	<u>(\$1,002,576)</u>	<u>(\$976,688)</u>
Contribution Deficiency / (Excess)	<u>\$0</u>	<u>\$0</u>	<u>\$0</u>	<u>\$0</u>	<u>\$0</u>	<u>\$0</u>	<u>\$0</u>	<u>\$0</u>	<u>\$0</u>	<u>\$0</u>
City's Covered-Employee Payroll										
Police	\$3,262,589	\$3,076,132	\$2,916,400	\$3,354,032	\$3,061,875	\$3,046,933	\$3,099,859	\$3,180,486	\$3,455,561	\$3,273,420
Fire	\$2,977,945	\$2,786,979	\$2,569,609	\$2,812,226	\$2,830,504	\$2,998,864	\$3,122,817	\$3,122,058	\$3,257,925	\$3,242,475
<u>Pension Contributions as a Percentage of Covered-Employee Payroll</u>										
Police	19.00%	19.00%	19.00%	19.00%	[1]	12.75%	12.75%	12.75%	12.75%	12.75%
Fire	23.50%	23.50%	23.50%	23.50%	[1]	17.25%	17.25%	17.25%	17.25%	17.25%

[1] – The portion of the City's contributions to fund pension obligations from January 1, 2013 thru May 31, 2013, for both police officers and firefighters was 14.81 percent and 19.31 percent, respectively. The portion of the City's contributions to fund pension obligations from June 1, 2013 thru December 31, 2013 for both police officers and firefighters was 16.65 percent and 21.15 percent, respectively.

City of Brook Park, Ohio

Required Supplementary Information

Schedule of Funding Progress OPEB

December 31, 2017

<u>Valuation Date</u>	<u>Actuarial Value of Assets (AVA)</u>	<u>Actuarial Accrued Liability (AAL)</u>	<u>Unfunded Actuarial Accrued Liability (UAAL) (3)-(2)</u>	<u>Funded Ratio (2)/(3)</u>
1	2	3	4	5
January 1, 2009	\$ 0	\$ 4,209,513	\$ 4,209,513	0%
January 1, 2010	\$ 0	\$ 4,213,588	\$ 4,213,588	0%
January 1, 2011	\$ 0	\$ 3,962,769	\$ 3,962,769	0%
January 1, 2012	\$ 0	\$ 4,120,492	\$ 4,120,492	0%
January 1, 2013	\$ 0	\$ 4,147,692	\$ 4,147,692	0%
January 1, 2014	\$ 0	\$ 3,980,994	\$ 3,980,994	0%
January 1, 2016	\$ 0	\$ 4,064,370	\$ 4,064,370	0%

Source:

- Actuarial Valuation Report on Other Post-Employment Benefits (OPEB) Funded Status for the fiscal year ending December 31, 2015 (latest available)
- Refer to Note 13 of the Basic Financial Statements for more information on the City's OPEB Plan.

City of Brook Park, Ohio

Notes to the Required Supplementary Information For The Year Ended December 31, 2017

OHIO PUBLIC EMPLOYEES RETIREMENT SYSTEM (OPERS)

Changes in benefit terms: There were no changes in benefit terms from the amounts reported for 2014-2017.

Changes in assumptions: There were no changes in methods and assumptions used in the calculation of actuarial determined contributions for 2014-2016. For 2017, the following changes of assumptions affected the total pension liability since the prior measurement date: (a) the expected investment return was reduced from 8.00% to 7.50%, (b) the expected long-term average wage inflation rate was reduced from 3.75% to 3.25%, (c) the expected long-term average price inflation rate was reduced from 3.00% to 2.50%, (d) Rates of withdrawal, retirement and disability were updated to reflect recent experience, (e) mortality rates were updated to the RP-2014 Health Annuitant Mortality Table, adjusted for mortality improvement back to the observant period base year of 2006 and then established the base year as 2015 (f) mortality rates used in evaluating disability allowances were updated to the RP-2014 Disabled Mortality tables, adjusted for mortality improvement back to the observation base year of 2006 and a base year of 2015 for males and 2010 for females (g) Mortality rates for a particular calendar year for both healthy and disabled retiree mortality tables are determined by applying the MP-2015 mortality improvement scale to the above described tables.

OHIO POLICE AND FIRE (OP&F) PENSION FUND

Changes in benefit terms: There were no changes in benefit terms from the amounts reported for 2014-2017.

Changes in assumptions: There were no changes in methods and assumptions used in the calculation of actuarial determined contributions for 2014-2017. See the notes to the basic financial statements for the methods and assumptions in this calculation.

City of Brook Park, Ohio

Fund Descriptions

Non-Major Governmental Funds

For The Year Ended December 31, 2017

Non-Major Special Revenue Funds

Street Maintenance Fund

The Street Maintenance Fund accounts for ninety-two and one half percent (92.5%) of the state gasoline tax and motor vehicle registration fees restricted for street maintenance and repair.

State Highway Fund

The State Highway Fund accounts for seven and one half percent (7.5%) of the state gasoline tax and motor vehicle registration fees restricted for maintenance and repair of state highways within the City.

Permissive Tax Fund

The Permissive Tax Fund accounts for additional motor vehicle registration fees restricted for maintenance and repair of streets within the City.

Economic Development Fund

The Economic Development Fund accounts for parking fees and proceeds received from the sale of City owned property committed for expenditures essential to the development of the City.

Brook Park Road Corridor Fund

The Brook Park Road Corridor Fund accounts for funds received from the City of Cleveland as a result of a legal settlement committed for attorney fees, land acquisition, grants or loans to Brook Park Road businesses and other expenditures related to the overall improvement of the corridor.

CDBG Fund

The CDBG Fund accounts for funds received from the Community Development Block Grant passed through from the Cuyahoga County. The grant funds were utilized for the W. 147th/Elm Street road project.

Special Recreation Fund

The Special Recreation Fund accounts for operations of City sponsored recreation programs committed by participation fees and facility rentals.

Law Enforcement Fund

The Law Enforcement Fund accounts for confiscated monies from criminal offenses and restricted, by state statute, for expenditures that would enhance the operation of the police department.

DWI Enforcement and Education Fund

The DWI Enforcement and Education Fund accounts for fine monies used by the law enforcement agency to pay costs related to DWI enforcement and for educating the public about laws governing the operation of a motor vehicle under the influence of alcohol.

Federal Forfeiture Fund

The Federal Forfeiture Fund accounts for confiscated monies from a Federal task force and restricted for expenditures that would enhance the operation of the police department.

City of Brook Park, Ohio

Fund Descriptions

Non-Major Governmental Funds

For The Year Ended December 31, 2017

Non-Major Special Revenue Funds (continued)

Community Diversion Fund

The Community Diversion Fund accounts for reimbursements received from Cuyahoga County Juvenile Court to promote and develop a community diversion program to address juvenile misdemeanor and status offenders.

Retiree Accrued Benefits Fund

The Retiree Accrued Benefits Fund accounts for funds allocated to pay for the accrued compensated absences paid out to employees upon retirement. Due to the implementation of GASB Statement No. 54, the fund was combined with the General Fund on the governmental fund financial statements but remained a separate fund in the budgetary schedules because it has a separate legally adopted budget.

Continuing Training Program Fund

The Continuing Training Program Fund accounts for restricted funds to provide for the training of the City's safety forces.

FEMA Fund

The FEMA Fund accounts for restricted funds that are used to reimburse costs incurred as a result of a natural disaster.

Police Pension Fund

The Police Pension Fund accounts for the accumulation of property taxes levied for the payment of current employer's pension contributions.

Fire Pension Fund

The Fire Pension Fund accounts for the accumulation of property taxes levied for the payment of current employer's pension contributions.

Southwest General Health Center Fund

The Southwest General Health Center Fund accounts for a special property tax levied to provide resources to support a health care facility.

Non-Major Debt Service Fund

General Obligation Debt Service Fund

The General Obligation Debt Service Fund accounts for the resources that are used for payment of principal and interest and fiscal charges on general obligation debt.

City of Brook Park, Ohio
Combining Balance Sheet
Non-Major Governmental Funds
December 31, 2017

	Nonmajor Special Revenue Funds	Nonmajor Debt Service Fund	Total Nonmajor Governmental Funds
Assets:			
Equity in Pooled Cash and Cash Equivalents	\$ 2,607,333	\$ 1,135,400	\$ 3,742,733
Accrued Interest Receivable	2,702	-	2,702
Accounts Receivable	2,000	-	2,000
Intergovernmental Receivable	471,177	760,240	1,231,417
Prepaid Items	392	-	392
Property Taxes Receivable	321,897	-	321,897
Special Assessments Receivable	-	60,227	60,227
Total Assets	<u>3,405,501</u>	<u>1,955,867</u>	<u>5,361,368</u>
Liabilities:			
Accrued Wages and Benefits	116,773	-	116,773
Contracts Payable	1,026	-	1,026
Intergovernmental Payable	312	-	312
Retainage Payable	36,395	-	36,395
Total Liabilities	<u>154,506</u>	<u>-</u>	<u>154,506</u>
Deferred Inflows of Resources:			
Property Taxes	307,667	-	307,667
Unavailable Revenue - Delinquent Property Taxes	14,230	-	14,230
Unavailable Revenue - Other	311,755	60,227	371,982
Total Deferred Inflows of Resources	<u>633,652</u>	<u>60,227</u>	<u>693,879</u>
Fund Balances:			
Nonspendable	392	-	392
Restricted	1,855,776	790,591	2,646,367
Committed	761,175	-	761,175
Assigned	-	1,105,049	1,105,049
Total Fund Balances	<u>2,617,343</u>	<u>1,895,640</u>	<u>4,512,983</u>
Total Liabilities, Deferred Inflows of Resources and Fund Balances	<u>\$ 3,405,501</u>	<u>\$ 1,955,867</u>	<u>\$ 5,361,368</u>

City of Brook Park, Ohio

Combining Statement of Revenues, Expenditures and Changes in Fund Balances

Non-Major Governmental Funds

For The Year Ended December 31, 2017

	Nonmajor Special Revenue Funds	Nonmajor Debt Service Fund	Total Nonmajor Governmental Funds
REVENUES			
Property Taxes	\$ 317,913	\$ -	\$ 317,913
Intergovernmental	972,611	-	972,611
Interest	19,159	-	19,159
Licenses and Permits	46,135	-	46,135
Fines and Forfeitures	6,450	-	6,450
Charges for Services	109,878	-	109,878
Special Assessments	-	60,216	60,216
All Other Revenues	85,477	-	85,477
Total Revenues	1,557,623	60,216	1,617,839
EXPENDITURES			
Security of Persons and Property:			
Police and Others	733,365	-	733,365
Fire	643,642	-	643,642
Public Health and Welfare	123,674	-	123,674
Leisure Time Activities	61,041	-	61,041
Community Development	469,896	-	469,896
Transportation	720,677	-	720,677
General Government	-	596	596
Capital Outlay	1,431,866	-	1,431,866
Debt Service:			
Principal Retirement	-	645,760	645,760
Interest and Fiscal Charges	-	342,249	342,249
Bond Issuance Costs	-	160,098	160,098
Total Expenditures	4,184,161	1,148,703	5,332,864
Excess of Revenues Over (Under) Expenditures	(2,626,538)	(1,088,487)	(3,715,025)
OTHER FINANCING SOURCES			
Premium on Debt Issuance	-	219,628	219,628
Transfer In	1,385,000	653,068	2,038,068
Total Other Financing Sources	1,385,000	872,696	2,257,696
Net Change in Fund Balances	(1,241,538)	(215,791)	(1,457,329)
Fund Balances - Beginning of Year	3,858,881	2,111,431	5,970,312
Fund Balances - End of Year	\$ 2,617,343	\$ 1,895,640	\$ 4,512,983

City of Brook Park, Ohio
Combining Balance Sheet
Non-Major Special Revenue Funds
December 31, 2017

	<u>Street Maintenance</u>	<u>State Highway</u>	<u>Permissive Tax</u>	<u>Economic Development</u>	<u>Brook Park Road Corridor</u>
ASSETS					
Equity in Pooled Cash and Cash Equivalents	\$ 312,054	\$ 663,010	\$ 180,474	\$ 254,335	\$ 57,835
Accrued Interest Receivable	591	1,256	342	-	-
Accounts Receivable	-	-	-	2,000	-
Intergovernmental Receivable	399,983	32,504	3,494	-	-
Prepaid Items	392	-	-	-	-
Property Taxes Receivable	-	-	-	-	-
Total Assets	<u>713,020</u>	<u>696,770</u>	<u>184,310</u>	<u>256,335</u>	<u>57,835</u>
LIABILITIES, DEFERRED INFLOWS OF RESOURCES AND FUND BALANCES					
Liabilities:					
Accrued Wages and Benefits	9,136	-	-	-	-
Contracts Payable	780	-	-	246	-
Intergovernmental Payable	312	-	-	-	-
Retainage Payable	31,172	-	-	5,223	-
<i>Total Liabilities</i>	<u>41,400</u>	<u>-</u>	<u>-</u>	<u>5,469</u>	<u>-</u>
Deferred Inflows of Resources:					
Property Taxes	-	-	-	-	-
Unavailable Revenue - Delinq. Property Taxes	-	-	-	-	-
Unavailable Revenue - Other	269,070	21,889	-	-	-
<i>Total Deferred Inflows of Resources</i>	<u>269,070</u>	<u>21,889</u>	<u>-</u>	<u>-</u>	<u>-</u>
Fund Balances:					
Nonspendable	392	-	-	-	-
Restricted	402,158	674,881	184,310	-	-
Committed	-	-	-	250,866	57,835
<i>Total Fund Balances (Deficit)</i>	<u>402,550</u>	<u>674,881</u>	<u>184,310</u>	<u>250,866</u>	<u>57,835</u>
Total Liabilities, Deferred Inflows of Resources and Fund Balances	<u>\$ 713,020</u>	<u>\$ 696,770</u>	<u>\$ 184,310</u>	<u>\$ 256,335</u>	<u>\$ 57,835</u>

(Continued)

City of Brook Park, Ohio
Combining Balance Sheet
Non-Major Special Revenue Funds
December 31, 2017

	CDBG	Special Recreation	Law Enforcement	DWI Enforcement & Education	Federal Forfeiture	Community Diversion
ASSETS						
Equity in Pooled Cash and Cash Equivalents	\$ 36,582	\$ 452,474	\$ 90,636	\$ 26,680	\$ 270,887	\$ 15,102
Accrued Interest Receivable	-	-	-	-	513	-
Accounts Receivable	-	-	-	-	-	-
Intergovernmental Receivable	-	-	-	-	-	-
Prepaid Items	-	-	-	-	-	-
Property Taxes Receivable	-	-	-	-	-	-
Total Assets	36,582	452,474	90,636	26,680	271,400	15,102
LIABILITIES, DEFERRED INFLOWS OF RESOURCES AND FUND BALANCES						
Liabilities:						
Accrued Wages and Benefits	-	-	-	-	-	-
Contracts Payable	-	-	-	-	-	-
Intergovernmental Payable	-	-	-	-	-	-
Retainage Payable	-	-	-	-	-	-
<i>Total Liabilities</i>	<i>-</i>	<i>-</i>	<i>-</i>	<i>-</i>	<i>-</i>	<i>-</i>
Deferred Inflows of Resources:						
Property Taxes	-	-	-	-	-	-
Unavailable Revenue - Delinq. Property Taxes	-	-	-	-	-	-
Unavailable Revenue - Other	-	-	-	-	-	-
<i>Total Deferred Inflows of Resources</i>	<i>-</i>	<i>-</i>	<i>-</i>	<i>-</i>	<i>-</i>	<i>-</i>
Fund Balances:						
Nonspendable	-	-	-	-	-	-
Restricted	36,582	-	90,636	26,680	271,400	15,102
Committed	-	452,474	-	-	-	-
<i>Total Fund Balances (Deficit)</i>	<i>36,582</i>	<i>452,474</i>	<i>90,636</i>	<i>26,680</i>	<i>271,400</i>	<i>15,102</i>
Total Liabilities, Deferred Inflows of Resources and Fund Balances	\$ 36,582	\$ 452,474	\$ 90,636	\$ 26,680	\$ 271,400	\$ 15,102

Continuing Training Program	FEMA	Police Pension	Fire Pension	Southwest General Health Center	Total Nonmajor Special Revenue Funds
\$ 8,833	\$ 54,663	\$ 84,540	\$ 99,203	\$ 25	\$ 2,607,333
-	-	-	-	-	2,702
-	-	-	-	-	2,000
14,400	-	7,028	7,028	6,740	471,177
-	-	-	-	-	392
-	-	111,724	111,620	98,553	321,897
<u>23,233</u>	<u>54,663</u>	<u>203,292</u>	<u>217,851</u>	<u>105,318</u>	<u>3,405,501</u>
-	-	52,955	54,682	-	116,773
-	-	-	-	-	1,026
-	-	-	-	-	312
-	-	-	-	-	36,395
<u>-</u>	<u>-</u>	<u>52,955</u>	<u>54,682</u>	<u>-</u>	<u>154,506</u>
-	-	106,800	106,700	94,167	307,667
-	-	4,924	4,920	4,386	14,230
-	-	7,028	7,028	6,740	311,755
<u>-</u>	<u>-</u>	<u>118,752</u>	<u>118,648</u>	<u>105,293</u>	<u>633,652</u>
-	-	-	-	-	392
23,233	54,663	31,585	44,521	25	1,855,776
-	-	-	-	-	761,175
<u>23,233</u>	<u>54,663</u>	<u>31,585</u>	<u>44,521</u>	<u>25</u>	<u>2,617,343</u>
<u>\$ 23,233</u>	<u>\$ 54,663</u>	<u>\$ 203,292</u>	<u>\$ 217,851</u>	<u>\$ 105,318</u>	<u>\$ 3,405,501</u>

City of Brook Park, Ohio

Combining Statement of Revenues, Expenditures and Changes in Fund Balances

Non-Major Special Revenue Funds

For The Year Ended December 31, 2017

	Street Maintenance	State Highway	Permissive Tax	Economic Development	Brook Park Road Corridor	CDBG	Special Recreation
REVENUES							
Property Taxes	\$ -	\$ -	\$ -	\$ -	\$ -	\$ -	\$ -
Intergovernmental	801,546	64,990	47,085	-	-	-	-
Interest	5,831	7,779	2,179	-	-	-	-
Fees, Licenses, and Permits	-	-	-	46,135	-	-	-
Fines and Forfeitures	-	-	-	-	-	-	-
Charges for Services	-	-	-	-	-	-	109,878
All Other Revenues	-	-	-	84,965	-	-	-
Total Revenues	807,377	72,769	49,264	131,100	-	-	109,878
EXPENDITURES							
Security of Persons and Property:							
Police and Others	-	-	-	-	-	-	-
Fire	-	-	-	-	-	-	-
Public Health and Welfare	-	-	-	-	-	-	-
Leisure Time Activities	-	-	-	-	-	-	61,041
Community Environment	-	-	-	444,896	25,000	-	-
Transportation	648,357	38,978	33,342	-	-	-	-
Capital Outlay	934,931	-	10,786	486,149	-	-	-
Total Expenditures	1,583,288	38,978	44,128	931,045	25,000	-	61,041
Excess of Revenues Over (Under) Expenditures	(775,911)	33,791	5,136	(799,945)	(25,000)	-	48,837
OTHER FINANCING SOURCES							
Transfer In	-	-	-	250,000	-	-	-
Total Other Financing Sources	-	-	-	250,000	-	-	-
Net Change in Fund Balances	(775,911)	33,791	5,136	(549,945)	(25,000)	-	48,837
Fund Balances - Beginning of Year	1,178,461	641,090	179,174	800,811	82,835	36,582	403,637
Fund Balances - End of Year	\$ 402,550	\$ 674,881	\$ 184,310	\$ 250,866	\$ 57,835	\$ 36,582	\$ 452,474

<u>Law Enforcement</u>	<u>DWI Enforcement & Education</u>	<u>Federal Forfeiture</u>	<u>Community Diversion</u>	<u>Continuing Training Program</u>	<u>FEMA</u>	<u>Police Pension</u>	<u>Fire Pension</u>	<u>Southwest General Health Center</u>	<u>Total Nonmajor Special Revenue Funds</u>
\$ -	\$ -	\$ -	\$ -	\$ -	\$ -	\$ 110,286	\$ 110,286	\$ 97,341	\$ 317,913
-	-	-	3,000	14,400	-	14,055	14,055	13,480	972,611
-	-	3,370	-	-	-	-	-	-	19,159
-	-	-	-	-	-	-	-	-	46,135
1,675	3,460	1,315	-	-	-	-	-	-	6,450
-	-	-	-	-	-	-	-	-	109,878
512	-	-	-	-	-	-	-	-	85,477
<u>2,187</u>	<u>3,460</u>	<u>4,685</u>	<u>3,000</u>	<u>14,400</u>	<u>-</u>	<u>124,341</u>	<u>124,341</u>	<u>110,821</u>	<u>1,557,623</u>
68,217	-	62,993	55	5,150	-	596,950	-	-	733,365
-	-	-	-	-	-	-	643,642	-	643,642
-	-	-	-	-	-	-	-	123,674	123,674
-	-	-	-	-	-	-	-	-	61,041
-	-	-	-	-	-	-	-	-	469,896
-	-	-	-	-	-	-	-	-	720,677
-	-	-	-	-	-	-	-	-	1,431,866
<u>68,217</u>	<u>-</u>	<u>62,993</u>	<u>55</u>	<u>5,150</u>	<u>-</u>	<u>596,950</u>	<u>643,642</u>	<u>123,674</u>	<u>4,184,161</u>
<u>(66,030)</u>	<u>3,460</u>	<u>(58,308)</u>	<u>2,945</u>	<u>9,250</u>	<u>-</u>	<u>(472,609)</u>	<u>(519,301)</u>	<u>(12,853)</u>	<u>(2,626,538)</u>
-	-	-	-	-	-	535,000	600,000	-	1,385,000
-	-	-	-	-	-	535,000	600,000	-	1,385,000
<u>(66,030)</u>	<u>3,460</u>	<u>(58,308)</u>	<u>2,945</u>	<u>9,250</u>	<u>-</u>	<u>62,391</u>	<u>80,699</u>	<u>(12,853)</u>	<u>(1,241,538)</u>
156,666	23,220	329,708	12,157	13,983	54,663	(30,806)	(36,178)	12,878	3,858,881
<u>\$ 90,636</u>	<u>\$ 26,680</u>	<u>\$ 271,400</u>	<u>\$ 15,102</u>	<u>\$ 23,233</u>	<u>\$ 54,663</u>	<u>\$ 31,585</u>	<u>\$ 44,521</u>	<u>\$ 25</u>	<u>\$ 2,617,343</u>

City of Brook Park, Ohio

Fund Descriptions

Agency Funds

For The Year Ended December 31, 2017

Agency Funds

Cash Bonds Held Fund

The Cash Bonds Held Fund accounts for deposits to insure the proper repair of street openings.

Mayor's Court Fund

The Mayor's Court Fund accounts for the collection and distribution of court fines and forfeitures.

Board of Building Standards Fund

The Board of Building Standards Fund accounts for the collection and distribution of State required building code fees.

Payroll Deduction Employees' Share Fund

The Payroll Deduction Employees' Share Fund accounts for employees' payroll deductions which are to be distributed to other agencies.

Pension Employee Withholding

The Pension Employee Withholding Fund accounts for employees' pension portion, which is to be distributed to other agencies.

City Withholding Fund

The City Withholding Fund accounts for City's pension portion, which is to be distributed to other agencies.

City of Brook Park, Ohio
Combining Statement of Assets and Liabilities
Agency Funds
December 31, 2017

	Cash Bonds Held	Mayor's Court	Board of Building Standards	Payroll Deduction Employees' Share	Pension Employee Withholding	City Withholding	Total
Assets							
Equity in Pooled Cash and Cash Equivalents	\$ 69,509	\$ -	\$ 3,129	\$ 33,501	\$ 126	\$ 3	\$ 106,268
Cash and Cash Equivalents: in Segregated Accounts	-	45,388	-	-	-	-	45,388
Total Assets	\$ 69,509	\$ 45,388	\$ 3,129	\$ 33,501	\$ 126	\$ 3	\$ 151,656
Liabilities							
Deposits Held and Due to Others	\$ 69,509	\$ 45,388	\$ 3,129	\$ 33,501	\$ 126	\$ 3	\$ 151,656

City of Brook Park, Ohio
Combining Statement of Changes in Assets and Liabilities
Agency Funds
For The Year Ended December 31, 2017

	Balance 12/31/2016	Additions	Deletions	Balance 12/31/2017
Cash Bonds Held				
Assets				
Equity in Pooled Cash and Cash Equivalents	\$ 75,009	\$ 2,500	\$ 8,000	\$ 69,509
Liabilities				
Deposits Held and Due to Others	\$ 75,009	\$ 2,500	\$ 8,000	\$ 69,509
Mayor's Court				
Assets				
Cash and Cash Equivalents: in Segregated Accounts	\$ 43,691	\$ 1,697	\$ -	\$ 45,388
Liabilities				
Deposits Held and Due to Others	\$ 43,691	\$ 1,697	\$ -	\$ 45,388
Board of Building Standards				
Assets				
Equity in Pooled Cash and Cash Equivalents	\$ 3,079	\$ 2,906	\$ 2,856	\$ 3,129
Liabilities				
Deposits Held and Due to Others	\$ 3,079	\$ 2,906	\$ 2,856	\$ 3,129
Payroll Deduction Employees' Share				
Assets				
Equity in Pooled Cash and Cash Equivalents	\$ 34,237	\$ 95,277	\$ 96,013	\$ 33,501
Liabilities				
Deposits Held and Due to Others	\$ 34,237	\$ 95,277	\$ 96,013	\$ 33,501
Pension Employee Withholding				
Assets				
Equity in Pooled Cash and Cash Equivalents	\$ 126	\$ -	\$ -	\$ 126
Liabilities				
Deposits Held and Due to Others	\$ 126	\$ -	\$ -	\$ 126
City Withholding				
Assets				
Equity in Pooled Cash and Cash Equivalents	\$ 3	\$ -	\$ -	\$ 3
Liabilities				
Deposits Held and Due to Others	\$ 3	\$ -	\$ -	\$ 3
Total - All Agency Funds				
Assets				
Equity in Pooled Cash and Cash Equivalents	\$ 112,454	\$ 100,683	\$ 106,869	\$ 106,268
Cash and Cash Equivalents: in Segregated Accounts	43,691	1,697	-	45,388
Total Assets	\$ 156,145	\$ 102,380	\$ 106,869	\$ 151,656
Liabilities				
Deposits Held and Due to Others	\$ 156,145	\$ 102,380	\$ 106,869	\$ 151,656

**Individual Fund
Schedules of Revenues, Expenditures and
Changes in Fund Balances -
Budget (Non – GAAP Budgetary Basis) and Actual**

City of Brook Park, Ohio

Schedule of Revenues, Expenditures and Changes in Fund Balance - Budget (Non-GAAP Budgetary Basis) and Actual

General Fund

For The Year Ended December 31, 2017

	Budgeted Amounts		Actual	Variance with Final Budget Positive (Negative)
	Original	Final		
Revenues:				
Property Taxes	\$ 1,542,871	\$ 1,536,865	\$ 1,536,865	\$ -
Income Taxes	16,268,600	16,582,000	16,558,288	(23,712)
Other Taxes	347,600	318,609	318,609	-
Intergovernmental	697,549	589,346	589,346	-
Interest	65,000	89,466	89,466	-
Licenses and Permits	742,060	650,839	643,068	(7,771)
Fines and Forfeitures	676,000	687,110	698,735	11,625
Rentals	53,299	53,299	53,299	-
Charges for Services	1,594,858	1,606,744	1,645,683	38,939
Contributions and Donations	1,825	1,825	1,825	-
All Other Revenues	273,381	605,852	563,059	(42,793)
Total Revenues	22,263,043	22,721,955	22,698,243	(23,712)
Expenditures:				
Current:				
Security of Persons and Property				
Correctional Facility				
Personal Services	200,765	200,765	194,498	6,267
Contractual Services	23,251	32,001	31,990	11
Supplies and Materials	15,139	14,389	11,546	2,843
Total Correctional Facility	239,155	247,155	238,034	9,121
School Guards				
Personal Services	81,345	81,345	80,730	615
Total School Guards	81,345	81,345	80,730	615
Fire Department				
Personal Services	3,443,395	3,529,627	3,520,804	8,823
Travel and Education	7,680	8,018	7,968	50
Contractual Services	133,371	146,770	137,054	9,716
Supplies and Materials	83,095	82,158	68,594	13,564
Total Fire Department	3,667,541	3,766,573	3,734,420	32,153
Police Department				
Personal Services	4,012,611	4,073,481	4,042,034	31,447
Travel and Education	7,500	7,600	5,387	2,213
Contractual Services	157,194	151,594	105,448	46,146
Supplies and Materials	143,384	148,884	130,247	18,637
Total Police Department	4,320,689	4,381,559	4,283,116	98,443

Continued

City of Brook Park, Ohio

Schedule of Revenues, Expenditures and Changes in Fund Balance - Budget (Non-GAAP Budgetary Basis) and Actual

General Fund (continued)

For The Year Ended December 31, 2017

	Budgeted Amounts		Actual	Variance with Final Budget Positive (Negative)
	Original	Final		
Animal Control				
Personal Services	90,901	96,674	94,062	2,612
Contractual Services	12,867	13,783	11,689	2,094
Supplies and Materials	5,686	8,770	7,584	1,186
Total Animal Control	109,454	119,227	113,335	5,892
Safety Director				
Personal Services	125,561	125,561	125,444	117
Contractual Services	250	307	63	244
Supplies and Materials	100	43	-	43
Total Safety Director	125,911	125,911	125,507	404
Safety Building				
Personal Services	121,749	121,749	120,304	1,445
Travel and Education	50	50	-	50
Contractual Services	479,249	502,895	496,559	6,336
Supplies and Materials	4,526	4,526	3,742	784
Total Safety Building	605,574	629,220	620,605	8,615
Safety Town				
Contractual Services	2,100	2,850	2,850	-
Supplies and Materials	350	211	211	-
Total Safety Town	2,450	3,061	3,061	-
Street Lighting				
Contractual Services	434,500	434,500	408,802	25,698
Supplies and Materials	2,017	2,017	401	1,616
Total Street Lighting	436,517	436,517	409,203	27,314
Traffic Lights				
Contractual Services	88,208	88,208	80,826	7,382
Total Traffic Lights	88,208	88,208	80,826	7,382

Continued

City of Brook Park, Ohio

Schedule of Revenues, Expenditures and Changes in Fund Balance - Budget (Non-GAAP Budgetary Basis) and Actual

General Fund (continued)

For The Year Ended December 31, 2017

	Budgeted Amounts		Actual	Variance with Final Budget Positive (Negative)
	Original	Final		
Disaster Services				
Personal Services	11,475	11,475	9,373	2,102
Contractual Services	2,250	2,401	2,351	50
Supplies and Materials	9,550	10,399	10,287	112
Total Disaster Services	23,275	24,275	22,011	2,264
Total Security of Persons and Property	9,700,119	9,903,051	9,710,848	192,203
Public Health & Welfare				
County Board of Health				
Contractual Services	83,453	75,327	75,327	-
Total County Board of Health	83,453	75,327	75,327	-
Office of Aging				
Personal Services	28,632	31,518	31,009	509
Contractual Services	301	301	117	184
Supplies and Materials	3,800	5,050	4,655	395
Total Office of Aging	32,733	36,869	35,781	1,088
Total Public Health and Welfare	116,186	112,196	111,108	1,088
Leisure Time Activities				
Recreation Commission				
Personal Services	6,927	6,927	6,234	693
Total Recreation Commission	6,927	6,927	6,234	693
Recreation Center				
Personal Services	565,729	565,729	497,150	68,579
Travel and Education	-	28	28	-
Contractual Services	251,885	249,357	220,051	29,306
Supplies and Materials	29,145	31,645	27,213	4,432
Other Expenses	500	520	520	-
Total Recreation Center	847,259	847,279	744,962	102,317
Home Day Celebration				
Personal Services	13,633	18,665	18,665	-
Contractual Services	45,250	40,063	40,007	56
Supplies and Materials	1,850	2,001	1,799	202
Total Home Day Celebration	60,733	60,729	60,471	258

Continued

City of Brook Park, Ohio

Schedule of Revenues, Expenditures and Changes in Fund Balance - Budget (Non-GAAP Budgetary Basis) and Actual

General Fund (continued)

For The Year Ended December 31, 2017

	Budgeted Amounts		Actual	Variance with Final Budget Positive (Negative)
	Original	Final		
Parks and Play Grounds				
Personal Services	201,319	203,403	202,797	606
Travel and Education	50	50	-	50
Contractual Services	70,200	70,129	64,104	6,025
Supplies and Materials	69,487	68,340	64,784	3,556
Total Parks and Play Grounds	341,156	342,022	331,785	10,237
Public Recreation				
Personal Services	23,321	27,939	25,178	2,761
Contractual Services	39,300	29,300	25,346	3,954
Supplies and Materials	2,855	2,855	-	2,855
Total Public Recreation	65,476	60,094	50,524	9,570
Total Leisure Time Activities	1,321,551	1,317,051	1,193,976	123,075
Community Development				
Planning Commission				
Personal Services	6,927	6,434	6,003	431
Supplies and Materials	190	190	-	190
Total Planning Commission	7,117	6,624	6,003	621
Community Development				
Personal Services	115,548	115,548	115,465	83
Travel and Education	500	500	187	313
Contractual Services	585	585	313	272
Supplies and Materials	100	100	49	51
Total Community Development	116,733	116,733	116,014	719
Board of Zoning Appeals				
Personal Services	6,927	7,420	7,389	31
Supplies and Materials	250	250	35	215
Total Board of Zoning Appeals	7,177	7,670	7,424	246
Building Department				
Personal Services	466,954	471,571	471,055	516
Travel and Education	1,100	1,829	1,434	395
Contractual Services	46,139	43,910	35,250	8,660
Supplies and Materials	3,434	4,934	3,174	1,760
Other Expenses	500	500	285	215
Total Building Department	518,127	522,744	511,198	11,546

Continued

City of Brook Park, Ohio

Schedule of Revenues, Expenditures and Changes in Fund Balance - Budget (Non-GAAP Budgetary Basis) and Actual

General Fund (continued)

For The Year Ended December 31, 2017

	Budgeted Amounts		Actual	Variance with Final Budget Positive (Negative)
	Original	Final		
Tree and Tree Lawns				
Personal Services	165,092	165,092	158,909	6,183
Travel and Education	-	45	45	-
Contractual Services	9,900	8,143	5,400	2,743
Supplies and Materials	12,860	24,571	21,208	3,363
Total Tree and Tree Lawns	187,852	197,851	185,562	12,289
Total Community Development	837,006	851,622	826,201	25,421
Public Works				
Service Director				
Personal Services	125,561	125,561	125,482	79
Travel and Education	75	25	-	25
Contractual Services	20,500	19,950	10,683	9,267
Supplies and Materials	400	1,000	841	159
Total Service Director	146,536	146,536	137,006	9,530
Service Building				
Personal Services	87,556	87,556	84,810	2,746
Travel and Education	-	35	35	-
Contractual Services	143,535	140,225	135,813	4,412
Supplies and Materials	40,283	93,556	56,518	37,038
Total Service Building	271,374	321,372	277,176	44,196
Sanitation Department				
Personal Services	481,208	481,208	476,507	4,701
Travel and Education	-	90	90	-
Contractual Services	10,040	1,240	1,000	240
Supplies and Materials	519,941	563,651	558,888	4,763
Total Sanitation Department	1,011,189	1,046,189	1,036,485	9,704
Sewers, Drains, and Pump Stations				
Personal Services	640,821	655,252	650,818	4,434
Travel and Education	100	100	45	55
Contractual Services	66,590	88,292	86,789	1,503
Supplies and Materials	121,039	99,337	74,460	24,877
Total Sewers, Drains, and Pump Stations	828,550	842,981	812,112	30,869
Total Public Works	2,257,649	2,357,078	2,262,779	94,299

Continued

City of Brook Park, Ohio

Schedule of Revenues, Expenditures and Changes in Fund Balance - Budget (Non-GAAP Budgetary Basis) and Actual

General Fund (continued)

For The Year Ended December 31, 2017

	Budgeted Amounts		Actual	Variance with Final Budget Positive (Negative)
	Original	Final		
Transportation				
Street Cleaning				
Personal Services	85,808	85,808	82,406	3,402
Supplies and Materials	3,250	4,000	3,913	87
Total Street Cleaning	89,058	89,808	86,319	3,489
Traffic Signs				
Personal Services	72,910	74,065	72,346	1,719
Supplies and Materials	3,550	4,300	3,909	391
Total Traffic Signs	76,460	78,365	76,255	2,110
Snow Removal				
Personal Services	59,110	76,428	64,286	12,142
Contractual Services	561	511	-	511
Supplies and Materials	307,119	289,851	224,882	64,969
Total Snow Removal	366,790	366,790	289,168	77,622
Total Transportation	532,308	534,963	451,742	83,221
General Government				
City Council				
Personal Services	143,121	143,121	141,646	1,475
Travel and Education	1,000	1,000	519	481
Contractual Services	47,756	47,755	31,448	16,307
Supplies and Materials	2,150	2,150	1,577	573
Total City Council	194,027	194,026	175,190	18,836
Clerk of Council				
Personal Services	100,727	106,500	102,819	3,681
Travel and Education	-	160	160	-
Contractual Services	2,700	2,700	1,977	723
Supplies and Materials	500	340	-	340
Total Clerk of Council	103,927	109,700	104,956	4,744

Continued

City of Brook Park, Ohio

Schedule of Revenues, Expenditures and Changes in Fund Balance - Budget (Non-GAAP Budgetary Basis) and Actual

General Fund (continued)

For The Year Ended December 31, 2017

	Budgeted Amounts		Actual	Variance with Final Budget Positive (Negative)
	Original	Final		
Mayor's Court				
Personal Services	153,187	158,036	157,034	1,002
Travel and Education	1,000	566	536	30
Contractual Services	19,047	19,047	10,805	8,242
Supplies and Materials	1,650	2,684	2,121	563
Total Mayor's Court	174,884	180,333	170,496	9,837
Civil Service Commission				
Personal Services	28,493	28,493	26,988	1,505
Travel and Education	250	250	-	250
Contractual Services	1,615	1,615	928	687
Supplies and Materials	3,200	3,200	901	2,299
Total Civil Service Commission	33,558	33,558	28,817	4,741
Mayor's Office				
Personal Services	305,190	309,808	307,401	2,407
Travel and Education	3,000	3,460	3,156	304
Contractual Services	12,789	13,789	11,373	2,416
Supplies and Materials	7,362	11,302	5,592	5,710
Total Mayor's Office	328,341	338,359	327,522	10,837
Human Resources				
Personal Services	101,771	101,771	101,710	61
Travel and Education	2,000	1,826	424	1,402
Contractual Services	5,851	8,075	7,977	98
Supplies and Materials	500	500	275	225
Total Human Resources	110,122	112,172	110,386	1,786
Public Properties				
Personal Services	312,769	314,501	309,069	5,432
Travel and Education	-	219	219	-
Contractual Services	8,150	7,130	5,820	1,310
Supplies and Materials	8,846	9,647	8,336	1,311
Total Public Properties	329,765	331,497	323,444	8,053

Continued

City of Brook Park, Ohio

Schedule of Revenues, Expenditures and Changes in Fund Balance - Budget (Non-GAAP Budgetary Basis) and Actual

General Fund (continued)

For The Year Ended December 31, 2017

	Budgeted Amounts		Actual	Variance with Final Budget Positive (Negative)
	Original	Final		
Legal Department				
Personal Services	258,720	270,265	258,413	11,852
Travel and Education	250	250	100	150
Contractual Services	2,020	1,902	734	1,168
Supplies and Materials	326	444	219	225
Total Legal Department	<u>261,316</u>	<u>272,861</u>	<u>259,466</u>	<u>13,395</u>
Finance Department				
Personal Services	395,033	398,532	395,655	2,877
Travel and Education	3,500	3,500	2,234	1,266
Contractual Services	83,419	79,559	74,370	5,189
Supplies and Materials	5,219	5,579	5,120	459
Total Finance Department	<u>487,171</u>	<u>487,170</u>	<u>477,379</u>	<u>9,791</u>
Tax Department				
Personal Services	246,114	246,114	237,081	9,033
Travel and Education	1,324	1,324	905	419
Contractual Services	85,016	83,416	72,219	11,197
Supplies and Materials	16,630	19,930	17,892	2,038
Other Expenses	940,000	940,000	186,455	753,545
Total Tax Department	<u>1,289,084</u>	<u>1,290,784</u>	<u>514,552</u>	<u>776,232</u>
Retirees				
Personal Services	228,000	293,000	217,407	75,593
Total Retirees	<u>228,000</u>	<u>293,000</u>	<u>217,407</u>	<u>75,593</u>
Mechanics				
Personal Services	575,524	583,606	582,100	1,506
Travel and Education	2,050	2,419	2,419	-
Contractual Services	700	131	92	39
Travel and Education	2,250	2,450	2,080	370
Total Mechanics	<u>580,524</u>	<u>588,606</u>	<u>586,691</u>	<u>1,915</u>
Engineering				
Contractual Services	48,000	48,000	48,000	-
Total Engineering	<u>48,000</u>	<u>48,000</u>	<u>48,000</u>	<u>-</u>

Continued

City of Brook Park, Ohio

Schedule of Revenues, Expenditures and Changes in Fund Balance - Budget (Non-GAAP Budgetary Basis) and Actual

General Fund (continued)

For The Year Ended December 31, 2017

	Budgeted Amounts		Actual	Variance with
	Original	Final		Final Budget Positive (Negative)
Lands and Buildings				
Personal Services	3,175	3,175	1,944	1,231
Contractual Services	114,476	110,105	100,040	10,065
Supplies and Materials	26,070	30,440	28,834	1,606
Total Lands and Buildings	143,721	143,720	130,818	12,902
Other General Government				
Personal Services	296,808	296,808	295,808	1,000
Travel and Education	19,000	20,484	20,484	-
Contractual Services	420,791	533,362	396,298	137,064
Supplies and Materials	298,302	331,453	308,577	22,876
Other Expenses	3,000	-	-	-
Total Other General Government	1,037,901	1,182,107	1,021,167	160,940
Total General Government	5,350,341	5,605,893	4,496,291	1,109,602
Total Expenditures	20,115,160	20,681,854	19,052,945	1,628,909
Excess of Revenues Over (Under) Expenditures	2,147,883	2,040,101	3,645,298	1,605,197
Other Financing Sources (Uses)				
Transfer In	347,000	347,000	-	(347,000)
Transfers Out	(4,677,000)	(5,042,000)	(4,674,000)	368,000
Total Other Financing Sources (Uses)	(4,330,000)	(4,695,000)	(4,674,000)	21,000
Net Change in Fund Balance	(2,182,117)	(2,654,899)	(1,028,702)	1,626,197
Cash Fund Balance - Beginning of Year	8,129,717	8,129,717	8,129,717	-
Current Year Encumbrances	-	-	270,439	270,439
Cash Fund Balance - End of Year	\$ 5,947,600	\$ 5,474,818	\$ 7,371,454	\$ 1,896,636

See accompanying notes to the basic financial statements.

City of Brook Park, Ohio

Schedule of Revenues, Expenditures and Changes in Fund Balance - Budget (Non-GAAP Budgetary Basis) and Actual

Capital Improvements Fund

For The Year Ended December 31, 2017

	Budgeted Amounts		Actual	Variance with Final Budget Positive (Negative)
	Original	Final		
Revenues:				
Income Taxes	\$ 2,831,400	\$ 2,868,000	\$ 2,862,072	\$ (5,928)
Intergovernmental	2,931,776	2,903,416	2,656,541	(246,875)
Charges for Services	16,597	16,462	16,462	-
Contributions and Donations	500	500	500	-
Total Revenues	5,780,273	5,788,378	5,535,575	(252,803)
Expenditures:				
Community Development				
Contractual Services	67,560	92,560	71,823	20,737
Total Community Development	67,560	92,560	71,823	20,737
Public Works				
Sewers and Drains				
Contractual Services	60,729	60,730	58,130	2,600
Total Public Works	60,729	60,730	58,130	2,600
Transportation				
Street Paving and Repair				
Contractual Services	517,761	526,552	462,360	64,192
Supplies and Materials	5,000	6,208	6,208	-
Total Transportation	522,761	532,760	468,568	64,192
General Government				
Income Tax Department				
Personal Services	54,054	54,054	51,823	2,231
Travel and Education	331	331	182	149
Contractual Services	21,229	20,829	11,365	9,464
Supplies and Materials	2,370	2,770	1,223	1,547
Other	235,000	235,000	46,614	188,386
Total Income Tax Department	312,984	312,984	111,207	201,777
Land and Buildings:				
Contractual Services	220,264	101,637	89,194	12,443
Supplies and Materials	-	2,000	1,728	272
Total Land and Buildings	220,264	103,637	90,922	12,715
Total General Government	533,248	416,621	202,129	214,492

Continued

City of Brook Park, Ohio

Schedule of Revenues, Expenditures and Changes in Fund Balance - Budget (Non-GAAP Budgetary Basis) and Actual Capital Improvements Fund (continued) **For The Year Ended December 31, 2017**

	Budgeted Amounts		Actual	Variance with Final Budget Positive (Negative)
	Original	Final		
Capital Outlay				
Building Department	40,117	40,117	4,852	35,265
Council	103,274	105,536	105,536	-
Finance Department	8,819	8,819	3,275	5,544
Fire Department	396,281	396,281	294,222	102,059
Lands and Buildings	5,353,553	5,263,087	5,109,351	153,736
Legal Department	10,261	10,261	3,222	7,039
Mayor's Office	16,603	16,603	6,930	9,673
Mechanics	5,000	5,000	3,085	1,915
Parks and Playgrounds	211,266	211,266	204,376	6,890
Police Department	326,993	326,992	207,220	119,772
Recreation Center	8,851	8,851	3,403	5,448
Safety Building	253,838	178,839	110,638	68,201
Sanitation	385,049	385,049	337,227	47,822
Service Building	8,996	8,996	5,760	3,236
Sewers and Drains	947,917	743,886	708,770	35,116
Snow Removal	97,692	107,258	107,258	-
Street Cleaning	37,339	37,339	37,339	-
Street Paving and Repair	7,007,046	6,997,046	6,689,149	307,897
Tax Department	6,229	6,229	1,597	4,632
Total Capital Outlay	15,225,124	14,857,455	13,943,210	914,245
Total Expenditures	16,409,422	15,960,126	14,743,860	1,216,266
Excess of Revenues Over (Under) Expenditures	(10,629,149)	(10,171,748)	(9,208,285)	963,463
Other Financing Sources (Uses)				
General Obligation Bonds Issued	5,387,479	4,979,736	4,979,736	-
Transfers In	5,050,000	3,210,000	3,189,000	(21,000)
Transfers Out	(653,068)	(653,068)	(653,068)	-
Total Other Financing Sources (Uses)	9,784,411	7,536,668	7,515,668	(21,000)
Net Change in Fund Balance	(844,738)	(2,635,080)	(1,692,617)	942,463
Cash Fund Balance - Beginning of Year	3,553,596	3,553,596	3,553,596	-
Current Year Encumbrances	-	-	5,256,594	5,256,594
Cash Fund Balance - End of Year	\$ 2,708,858	\$ 918,516	\$ 7,117,573	\$ 6,199,057

See accompanying notes to the basic financial statements.

City of Brook Park, Ohio

Schedule of Revenues, Expenditures and Changes in Fund Balance - Budget (Non-GAAP Budgetary Basis) and Actual

Street Maintenance Fund

For The Year Ended December 31, 2017

	Budgeted Amounts		Actual	Variance with Final Budget Positive (Negative)
	Original	Final		
Revenues:				
Intergovernmental	\$ 779,567	\$ 801,768	\$ 801,768	\$ -
Interest	7,000	6,185	6,185	-
Total Revenues	<u>786,567</u>	<u>807,953</u>	<u>807,953</u>	<u>-</u>
Expenditures:				
Current:				
Transportation				
Street Paving and Repair				
Personal Services	557,021	557,021	550,227	6,794
Travel and Education	100	134	134	-
Contractual Services	77,702	77,923	73,620	4,303
Supplies and Materials	56,214	75,959	38,264	37,695
Total Transportation	<u>691,037</u>	<u>711,037</u>	<u>662,245</u>	<u>48,792</u>
Capital Outlay				
Contractual Services	<u>1,096,856</u>	<u>1,076,856</u>	<u>1,076,856</u>	<u>-</u>
Total Capital Outlay	<u>1,096,856</u>	<u>1,076,856</u>	<u>1,076,856</u>	<u>-</u>
Total Expenditures	<u>1,787,893</u>	<u>1,787,893</u>	<u>1,739,101</u>	<u>48,792</u>
Net Change in Fund Balance	(1,001,326)	(979,940)	(931,148)	48,792
Cash Fund Balance - Beginning of Year	1,055,611	1,055,611	1,055,611	-
Current Year Encumbrances	-	-	187,591	187,591
Cash Fund Balance - End of Year	<u>\$ 54,285</u>	<u>\$ 75,671</u>	<u>\$ 312,054</u>	<u>\$ 236,383</u>

City of Brook Park, Ohio

Schedule of Revenues, Expenditures and Changes in Fund Balance - Budget (Non-GAAP Budgetary Basis) and Actual

State Highway Fund

For The Year Ended December 31, 2017

	Budgeted Amounts		Actual	Variance with Final Budget Positive (Negative)
	Original	Final		
Revenues:				
Intergovernmental	\$ 63,208	\$ 65,009	\$ 65,009	\$ -
Interest	5,000	7,087	7,087	-
Total Revenues	<u>68,208</u>	<u>72,096</u>	<u>72,096</u>	<u>-</u>
Expenditures:				
Current:				
Transportation				
Street Paving and Repair				
Personal Services	-	227	227	-
Supplies and Materials	30,958	80,959	71,360	9,599
Total Expenditures	<u>30,958</u>	<u>81,186</u>	<u>71,587</u>	<u>9,599</u>
Net Change in Fund Balance	37,250	(9,090)	509	9,599
Cash Fund Balance - Beginning of Year	629,893	629,893	629,893	-
Current Year Encumbrances	-	-	32,608	32,608
Cash Fund Balance - End of Year	<u>\$ 667,143</u>	<u>\$ 620,803</u>	<u>\$ 663,010</u>	<u>\$ 42,207</u>

City of Brook Park, Ohio

Schedule of Revenues, Expenditures and Changes in Fund Balance - Budget (Non-GAAP Budgetary Basis) and Actual

Permissive Tax Fund

For The Year Ended December 31, 2017

	Budgeted Amounts		Actual	Variance with Final Budget Positive (Negative)
	Original	Final		
Revenues:				
Intergovernmental	\$ 50,824	\$ 47,381	\$ 47,381	\$ -
Interest	1,100	2,011	2,011	-
Total Revenues	<u>51,924</u>	<u>49,392</u>	<u>49,392</u>	<u>-</u>
Expenditures:				
Current:				
Transportation				
Street Paving and Repair				
Contractual Services	8,308	8,308	8,308	-
Supplies and Materials	50,000	70,000	35,336	34,664
Total Transportation	<u>58,308</u>	<u>78,308</u>	<u>43,644</u>	<u>34,664</u>
Capital Outlay				
Contractual Services	128,075	108,075	108,075	-
Total Capital Outlay	<u>128,075</u>	<u>108,075</u>	<u>108,075</u>	<u>-</u>
Total Expenditures	<u>186,383</u>	<u>186,383</u>	<u>151,719</u>	<u>34,664</u>
Net Change in Fund Balance	(134,459)	(136,991)	(102,327)	34,664
Cash Fund Balance - Beginning of Year	194,138	194,138	194,138	-
Current Year Encumbrances	-	-	88,663	88,663
Cash Fund Balance - End of Year	<u>\$ 59,679</u>	<u>\$ 57,147</u>	<u>\$ 180,474</u>	<u>\$ 123,327</u>

City of Brook Park, Ohio

Schedule of Revenues, Expenditures and Changes in Fund Balance - Budget (Non-GAAP Budgetary Basis) and Actual

Economic Development Fund

For The Year Ended December 31, 2017

	Budgeted Amounts		Actual	Variance with Final Budget Positive (Negative)
	Original	Final		
Revenues:				
Fees, Licenses, and Permits	\$ 35,125	\$ 46,135	\$ 46,135	\$ -
All Other Revenues	92,500	82,965	82,965	-
Total Revenues	<u>127,625</u>	<u>129,100</u>	<u>129,100</u>	<u>-</u>
Expenditures:				
Current:				
Community Development				
Travel and Education	3,000	3,395	3,395	-
Contractual Services	627,330	628,580	611,255	17,325
Supplies and Materials	3,448	1,803	1,595	208
Other	750	750	410	340
Total Community Development	<u>634,528</u>	<u>634,528</u>	<u>616,655</u>	<u>17,873</u>
Capital Outlay				
Contractual Services	544,315	544,315	533,858	10,457
Total Capital Outlay	<u>544,315</u>	<u>544,315</u>	<u>533,858</u>	<u>10,457</u>
Total Expenditures	<u>1,178,843</u>	<u>1,178,843</u>	<u>1,150,513</u>	<u>28,330</u>
Excess of Revenues Over (Under) Expenditures	(1,051,218)	(1,049,743)	(1,021,413)	28,330
Other Financing Sources				
Transfers In	250,000	250,000	250,000	-
Total Other Financing Sources	<u>250,000</u>	<u>250,000</u>	<u>250,000</u>	<u>-</u>
Net Change in Fund Balance	(801,218)	(799,743)	(771,413)	28,330
Cash Fund Balance - Beginning of Year	814,208	814,208	814,208	-
Current Year Encumbrances	-	-	211,540	211,540
Cash Fund Balance - End of Year	<u>\$ 12,990</u>	<u>\$ 14,465</u>	<u>\$ 254,335</u>	<u>\$ 239,870</u>

City of Brook Park, Ohio

Schedule of Revenues, Expenditures and Changes in Fund Balance -
Budget (Non-GAAP Budgetary Basis) and Actual

Brook Park Road Corridor Fund

For The Year Ended December 31, 2017

	Budgeted Amounts		Actual	Variance with Final Budget Positive (Negative)
	Original	Final		
Expenditures:				
Current:				
Community Development				
Contractual Services	\$ 25,000	\$ 25,000	\$ 25,000	\$ -
Total Expenditures	<u>25,000</u>	<u>25,000</u>	<u>25,000</u>	<u>-</u>
Net Change in Fund Balance	(25,000)	(25,000)	(25,000)	-
Cash Fund Balance - Beginning of Year	82,835	82,835	82,835	-
Cash Fund Balance - End of Year	<u>\$ 57,835</u>	<u>\$ 57,835</u>	<u>\$ 57,835</u>	<u>\$ -</u>

City of Brook Park, Ohio

Schedule of Revenues, Expenditures and Changes in Fund Balance -
Budget (Non-GAAP Budgetary Basis) and Actual
CDBG Fund

For The Year Ended December 31, 2017

	Budgeted Amounts		Actual	Variance with Final Budget Positive (Negative)
	Original	Final		
Cash Fund Balance - Beginning of Year	\$ 36,582	\$ 36,582	\$ 36,582	\$ -
Cash Fund Balance - End of Year	<u>\$ 36,582</u>	<u>\$ 36,582</u>	<u>\$ 36,582</u>	<u>\$ -</u>

City of Brook Park, Ohio

Schedule of Revenues, Expenditures and Changes in Fund Balance - Budget (Non-GAAP Budgetary Basis) and Actual

Special Recreation Fund

For The Year Ended December 31, 2017

	Budgeted Amounts		Actual	Variance with Final Budget Positive (Negative)
	Original	Final		
Revenues:				
All Other Revenues	\$ 94,433	\$ 109,878	\$ 109,878	\$ -
Total Revenues	<u>94,433</u>	<u>109,878</u>	<u>109,878</u>	<u>-</u>
Expenditures:				
Current:				
Leisure Time Activities				
Public Recreation				
Parks & Playground				
Contractual Services	10,000	11,021	9,413	1,608
Supplies and Materials	64,430	73,408	68,157	5,251
Other	4,000	4,000	1,805	2,195
Capital Outlay	240,000	230,000	5,656	224,344
Total Leisure Time Activities	<u>318,430</u>	<u>318,429</u>	<u>85,031</u>	<u>233,398</u>
Total Expenditures	<u>318,430</u>	<u>318,429</u>	<u>85,031</u>	<u>233,398</u>
Net Change in Fund Balance	(223,997)	(208,551)	24,847	233,398
Cash Fund Balance - Beginning of Year	411,177	411,177	411,177	-
Current Year Encumbrances	-	-	16,450	16,450
Cash Fund Balance - End of Year	<u>\$ 187,180</u>	<u>\$ 202,626</u>	<u>\$ 452,474</u>	<u>\$ 249,848</u>

City of Brook Park, Ohio

Schedule of Revenues, Expenditures and Changes in Fund Balance - Budget (Non-GAAP Budgetary Basis) and Actual

Law Enforcement Fund

For The Year Ended December 31, 2017

	Budgeted Amounts		Actual	Variance with Final Budget Positive (Negative)
	Original	Final		
Revenues:				
Fines and Forfeitures	\$ 320	\$ 1,675	\$ 1,675	\$ -
All Other Revenues	500	512	512	-
Total Revenues	<u>820</u>	<u>2,187</u>	<u>2,187</u>	<u>-</u>
Expenditures:				
Current:				
Security of Persons and Property				
Police and Others				
Travel and Education	-	1,500	1,140	360
Supplies and Materials	2,000	3,000	2,511	489
Capital Outlay	83,000	80,500	65,991	14,509
Total Security of Persons & Property	<u>85,000</u>	<u>85,000</u>	<u>69,642</u>	<u>15,358</u>
Total Expenditures	<u>85,000</u>	<u>85,000</u>	<u>69,642</u>	<u>15,358</u>
Net Change in Fund Balance	(84,180)	(82,813)	(67,455)	15,358
Cash Fund Balance - Beginning of Year	156,666	156,666	156,666	-
Current Year Encumbrances	-	-	1,425	1,425
Cash Fund Balance - End of Year	<u>\$ 72,486</u>	<u>\$ 73,853</u>	<u>\$ 90,636</u>	<u>\$ 16,783</u>

City of Brook Park, Ohio

Schedule of Revenues, Expenditures and Changes in Fund Balance -
Budget (Non-GAAP Budgetary Basis) and Actual

DWI Enforcement and Education Fund

For The Year Ended December 31, 2017

	Budgeted Amounts		Actual	Variance with Final Budget Positive (Negative)
	Original	Final		
Revenues:				
Fines and Forfeitures	\$ 962	\$ 3,460	\$ 3,460	\$ -
Total Revenues	<u>962</u>	<u>3,460</u>	<u>3,460</u>	<u>-</u>
Net Change in Fund Balance	962	3,460	3,460	-
Cash Fund Balance - Beginning of Year	23,220	23,220	23,220	-
Cash Fund Balance - End of Year	<u>\$ 24,182</u>	<u>\$ 26,680</u>	<u>\$ 26,680</u>	<u>\$ -</u>

City of Brook Park, Ohio

Schedule of Revenues, Expenditures and Changes in Fund Balance - Budget (Non-GAAP Budgetary Basis) and Actual

Federal Forfeiture Fund

For The Year Ended December 31, 2017

	Budgeted Amounts		Actual	Variance with Final Budget Positive (Negative)
	Original	Final		
Revenues:				
Interest	\$ 2,650	\$ 3,170	\$ 3,170	\$ -
All Other Revenues	9,776	1,315	1,315	-
Total Revenues	<u>12,426</u>	<u>4,485</u>	<u>4,485</u>	<u>-</u>
Expenditures:				
Current:				
Security of Persons and Property				
Police and Others				
Travel and Education	3,000	3,000	350	2,650
Supplies and Materials	2,380	2,380	990	1,390
Capital Outlay	114,756	114,756	82,551	32,205
Total Expenditures	<u>120,136</u>	<u>120,136</u>	<u>83,891</u>	<u>36,245</u>
Net Change in Fund Balance	(107,710)	(115,651)	(79,406)	36,245
Cash Fund Balance - Beginning of Year	349,576	349,576	349,576	-
Current Year Encumbrances	-	-	717	717
Cash Fund Balance - End of Year	<u>\$ 241,866</u>	<u>\$ 233,925</u>	<u>\$ 270,887</u>	<u>\$ 36,962</u>

City of Brook Park, Ohio

Schedule of Revenues, Expenditures and Changes in Fund Balance -
Budget (Non-GAAP Budgetary Basis) and Actual

Community Diversion Fund

For The Year Ended December 31, 2017

	Budgeted Amounts		Actual	Variance with Final Budget Positive (Negative)
	Original	Final		
Revenues:				
Intergovernmental	\$ 2,800	\$ 3,000	\$ 3,000	\$ -
Total Revenues	<u>2,800</u>	<u>3,000</u>	<u>3,000</u>	<u>-</u>
Expenditures:				
Current:				
Security of Persons and Property				
Police and Others				
Personal Services	577	577	40	537
Contractual Services	50	50	15	35
Supplies and Materials	50	50	-	50
Total Expenditures	<u>677</u>	<u>677</u>	<u>55</u>	<u>622</u>
Net Change in Fund Balance	2,123	2,323	2,945	622
Cash Fund Balance - Beginning of Year	12,157	12,157	12,157	-
Cash Fund Balance - End of Year	<u>\$ 14,280</u>	<u>\$ 14,480</u>	<u>\$ 15,102</u>	<u>\$ 622</u>

City of Brook Park, Ohio

Schedule of Revenues, Expenditures and Changes in Fund Balance - Budget (Non-GAAP Budgetary Basis) and Actual

Retiree Accrued Benefits Fund

For The Year Ended December 31, 2017

	Budgeted Amounts		Actual	Variance with Final Budget Positive (Negative)
	Original	Final		
Expenditures:				
Current:				
Security of Persons and Property				
Fire				
Personal Services	15,000	15,000	12,178	2,822
Total Security of Persons & Property	15,000	15,000	12,178	2,822
Leisure Time Activities				
Recreation Center				
Personal Services	20,000	30,000	20,325	9,675
Total Leisure Time Activities	20,000	30,000	20,325	9,675
Public Works				
Sewers and Drains				
Personal Services	35,000	75,000	64,414	10,586
Total Public Works	35,000	75,000	64,414	10,586
Transportation				
Street Cleaning				
Personal Services	5,000	5,000	2,599	2,401
Total Transportation	5,000	5,000	2,599	2,401
Total Expenditures	75,000	125,000	99,516	25,484
Excess of Revenues Over (Under) Expenditures	(75,000)	(125,000)	(99,516)	25,484
Other Financing Sources				
Transfers In	50,000	100,000	100,000	-
Total Other Financings Sources	50,000	100,000	100,000	-
Net Change in Fund Balance	(25,000)	(25,000)	484	25,484
Cash Fund Balance - Beginning of Year	27,653	27,653	27,653	-
Cash Fund Balance - End of Year	\$ 2,653	\$ 2,653	\$ 28,137	\$ 25,484

City of Brook Park, Ohio

Schedule of Revenues, Expenditures and Changes in Fund Balance - Budget (Non-GAAP Budgetary Basis) and Actual

Continuing Training Program Fund

For The Year Ended December 31, 2017

	Budgeted Amounts		Actual	Variance with Final Budget Positive (Negative)
	Original	Final		
Revenues:				
Intergovernmental	\$ 10,000	\$ 7,920	\$ 7,920	\$ -
Total Revenues	<u>10,000</u>	<u>7,920</u>	<u>7,920</u>	<u>-</u>
Expenditures:				
Current:				
Security of Persons and Property				
Travel and Education	\$ 5,500	\$ 6,500	\$ 5,150	\$ 1,350
Total Expenditures	<u>5,500</u>	<u>6,500</u>	<u>5,150</u>	<u>1,350</u>
Net Change in Fund Balance	4,500	1,420	2,770	1,350
Cash Fund Balance - Beginning of Year	6,063	6,063	6,063	-
Cash Fund Balance - End of Year	<u>\$ 10,563</u>	<u>\$ 7,483</u>	<u>\$ 8,833</u>	<u>\$ 1,350</u>

City of Brook Park, Ohio

Schedule of Revenues, Expenditures and Changes in Fund Balance -
 Budget (Non-GAAP Budgetary Basis) and Actual

FEMA Fund

For The Year Ended December 31, 2017

	Budgeted Amounts		Actual	Variance with Final Budget Positive (Negative)
	Original	Final		
Cash Fund Balance - Beginning of Year	\$ 54,663	\$ 54,663	\$ 54,663	\$ -
Cash Fund Balance - End of Year	\$ 54,663	\$ 54,663	\$ 54,663	\$ -

City of Brook Park, Ohio

Schedule of Revenues, Expenditures and Changes in Fund Balance - Budget (Non-GAAP Budgetary Basis) and Actual

Police Pension Fund

For The Year Ended December 31, 2017

	Budgeted Amounts		Actual	Variance with Final Budget Positive (Negative)
	Original	Final		
Revenues:				
Property Taxes	\$ 102,943	\$ 110,286	\$ 110,286	\$ -
Intergovernmental	14,168	14,055	14,055	-
Total Revenues	<u>117,111</u>	<u>124,341</u>	<u>124,341</u>	<u>-</u>
Expenditures:				
Current:				
Security of Persons and Property				
Police and Others				
Personal Services	623,362	638,362	588,939	49,423
Total Expenditures	<u>623,362</u>	<u>638,362</u>	<u>588,939</u>	<u>49,423</u>
Excess of Revenues Over (Under) Expenditures	(506,251)	(514,021)	(464,598)	49,423
Other Financing Sources				
Transfers In	520,000	535,000	535,000	-
Total Other Financing Sources	<u>520,000</u>	<u>535,000</u>	<u>535,000</u>	<u>-</u>
Net Change in Fund Balance	13,749	20,979	70,402	49,423
Cash Fund Balance - Beginning of Year	14,138	14,138	14,138	-
Cash Fund Balance - End of Year	<u>\$ 27,887</u>	<u>\$ 35,117</u>	<u>\$ 84,540</u>	<u>\$ 49,423</u>

City of Brook Park, Ohio

Schedule of Revenues, Expenditures and Changes in Fund Balance - Budget (Non-GAAP Budgetary Basis) and Actual

Fire Pension Fund

For The Year Ended December 31, 2017

	Budgeted Amounts		Actual	Variance with Final Budget Positive (Negative)
	Original	Final		
Revenues:				
Property Taxes	\$ 102,943	\$ 110,286	\$ 110,286	\$ -
Intergovernmental	14,168	14,055	14,055	-
Total Revenues	<u>117,111</u>	<u>124,341</u>	<u>124,341</u>	<u>-</u>
Expenditures:				
Current:				
Fire				
Personal Services	688,442	698,442	640,164	58,278
Total Expenditures	<u>688,442</u>	<u>698,442</u>	<u>640,164</u>	<u>58,278</u>
Excess of Revenues Over (Under) Expenditures	(571,331)	(574,101)	(515,823)	58,278
Other Financing Sources				
Transfers In	590,000	600,000	600,000	-
Total Other Financing Sources	<u>590,000</u>	<u>600,000</u>	<u>600,000</u>	<u>-</u>
Net Change in Fund Balance	18,669	25,899	84,177	58,278
Cash Fund Balance - Beginning of Year	15,026	15,026	15,026	-
Cash Fund Balance - End of Year	<u>\$ 33,695</u>	<u>\$ 40,925</u>	<u>\$ 99,203</u>	<u>\$ 58,278</u>

City of Brook Park, Ohio

Schedule of Revenues, Expenditures and Changes in Fund Balance - Budget (Non-GAAP Budgetary Basis) and Actual

Southwest General Health Center Fund

For The Year Ended December 31, 2017

	Budgeted Amounts		Actual	Variance with Final Budget Positive (Negative)
	Original	Final		
Revenues:				
Property Taxes	\$ 91,247	\$ 97,341	\$ 97,341	\$ -
Intergovernmental	13,584	13,480	13,480	-
Total Revenues	104,831	110,821	110,821	-
Expenditures:				
Current:				
Public Health and Welfare				
Contractual Services	117,709	123,674	123,674	-
Total Expenditures	117,709	123,674	123,674	-
Net Change in Fund Balance	(12,878)	(12,853)	(12,853)	-
Cash Fund Balance - Beginning of Year	12,878	12,878	12,878	-
Cash Fund Balance - End of Year	\$ -	\$ 25	\$ 25	\$ -

City of Brook Park, Ohio

Schedule of Revenues, Expenditures and Changes in Fund Balance - Budget (Non-GAAP Budgetary Basis) and Actual

General Obligation Fund

For The Year Ended December 31, 2017

	Budgeted Amounts		Actual	Variance with Final Budget Positive (Negative)
	Original	Final		
Revenues:				
Intergovernmental	\$ 63,353	\$ 63,353	\$ 63,353	\$ -
Special Assessments	58,400	60,216	60,216	-
Total Revenues	<u>121,753</u>	<u>123,569</u>	<u>123,569</u>	<u>-</u>
Expenditures:				
Current:				
General Government				
Contractual Services	850	850	596	254
Total General Government	<u>850</u>	<u>850</u>	<u>596</u>	<u>254</u>
Debt Service:				
Principal	525,689	645,760	645,760	-
Interest & Fiscal Charges	247,987	340,303	340,303	-
Bond Issuance Costs	-	161,904	161,904	-
Total Debt Service	<u>773,676</u>	<u>1,147,967</u>	<u>1,147,967</u>	<u>-</u>
Total Expenditures	<u>774,526</u>	<u>1,148,817</u>	<u>1,148,563</u>	<u>254</u>
Excess of Revenues Over (Under) Expenditures	(652,773)	(1,025,248)	(1,024,994)	254
Other Financing Sources				
Transfers In	653,068	653,068	653,068	-
Total Other Financing Sources	<u>653,068</u>	<u>872,556</u>	<u>872,556</u>	<u>-</u>
Net Change in Fund Balance	295	(152,692)	(152,438)	254
Cash Fund Balance - Beginning of Year	<u>1,287,838</u>	<u>1,287,838</u>	<u>1,287,838</u>	<u>-</u>
Cash Fund Balance - End of Year	<u>\$ 1,288,133</u>	<u>\$ 1,135,146</u>	<u>\$ 1,135,400</u>	<u>\$ 254</u>

City of Brook Park, Ohio

Schedule of Revenues, Expenditures and Changes in Fund Equity-
Budget (Non-GAAP Budgetary Basis) and Actual

Self Insured Medical Benefits Fund

For The Year Ended December 31, 2017

	Budgeted Amounts		Actual	Variance with Final Budget Positive (Negative)
	Original	Final		
Revenues:				
Charges for Services	\$ 1,738,887	\$ 1,792,710	\$ 62,889	\$ (1,729,821)
Total Revenues	<u>1,738,887</u>	<u>1,792,710</u>	<u>62,889</u>	<u>(1,729,821)</u>
Expenses				
Current:				
Fringe Benefits	2,047,319	2,047,319	181,989	1,865,330
Contractual Services	750	750	631	119
Total Expenses	<u>2,048,069</u>	<u>2,048,069</u>	<u>182,620</u>	<u>1,865,449</u>
Net Change in Fund Equity	(309,182)	(255,359)	(119,731)	135,628
Cash Fund Equity - Beginning of Year	<u>3,187,691</u>	<u>3,187,691</u>	<u>3,187,691</u>	<u>-</u>
Cash Fund Equity - End of Year	<u>\$ 2,878,509</u>	<u>\$ 2,932,332</u>	<u>\$ 3,067,960</u>	<u>\$ 135,628</u>

This page is intentionally left blank

STATISTICAL SECTION

City of Brook Park, Ohio

Statistical Section

This part of City's comprehensive annual financial report presents detailed information as a context for understanding what the information in the financial statements, note disclosures, and required supplementary information says about the City's overall financial health.

<u>Contents</u>	<u>Page(s)</u>
Financial Trends These schedules contain trend information to help the reader understand how the City's financial performance and well-being have changed over time.	S2 – S7
Revenue Capacity These schedules contain information to help the reader assess the City's most significant local revenue source, the property tax.	S8 - S13
Debt Capacity These schedules present information to help the reader assess the affordability of the City's current levels of outstanding debt and the City's ability to issue additional debt in the future.	S14–S17
Economic and Demographic Information These schedules offer economic and demographic indicators to help the reader understand the environment within which the City's financial activities take place.	S18-S19
Operating Information These schedules contain service data to help the reader understand how the information in the City's financial report relates to the services the City provides and the activities it performs.	S20-S23

Sources: Unless otherwise noted, the information in these schedules is derived from the comprehensive annual financial reports for the relevant year.

City of Brook Park, Ohio
Net Position by Component
Accrual Basis of Accounting
Last Ten Fiscal Years

Table 1

	2008	2009	2010	Restated (1) 2011	2012	2013	2014	Restated (2) 2015	2016	2017
Governmental activities:										
Net investment in										
Capital assets	\$ 63,019,962	\$ 66,056,261	\$ 69,340,252	\$ 69,624,618	\$ 69,659,655	\$ 68,500,606	\$ 67,365,271	\$ 66,736,815	\$ 67,797,950	\$ 71,280,520
Restricted for:										
Capital projects	10,585,857	6,705,275	5,173,026	5,358,279	3,309,139	3,377,216	5,257,973	1,841,871	2,148,752	6,592,223
Debt service	541,282	574,620	651,203	634,751	730,029	747,956	803,224	3,994,770	3,726,530	1,162,932
Other purposes	272,025	366,682	501,409	615,393	1,180,925	1,257,622	1,270,567	1,156,438	219,890	298,572
Recreation	-	-	-	-	-	-	-	-	403,637	452,474
Public Safety	-	-	-	-	-	-	-	-	509,594	388,716
Economic development	1,604,073	1,341,950	507,980	357,863	456,696	449,730	304,469	1,263,245	800,811	250,866
Street paving and repair	1,079,360	1,240,057	1,402,084	1,527,587	1,646,532	1,778,891	2,023,577	2,441,997	2,284,811	1,552,700
Unrestricted	6,171,898	5,585,468	5,286,791	5,119,842	5,897,052	6,066,741	6,952,423	(7,673,180)	(7,147,730)	(9,941,237)
Total net position - governmental activities	\$ 83,274,457	\$ 81,870,313	\$ 82,862,745	\$ 83,238,333	\$ 82,880,028	\$ 82,178,762	\$ 83,977,504	\$ 69,761,956	\$ 70,744,245	\$ 72,037,766

(1) - Restatement done due to the implementation of GASB 65

(2) - Restatement done due to the implementation of GASB 68

Note: A portion of the 2012 net position was reclassified between restricted and unrestricted. This reclass did not affect the total 2012 net position.

City of Brook Park, Ohio
Changes in Net Position
Accrual Basis of Accounting
Last Ten Fiscal Years

Table 2

	2008	2009	2010	2011	2012	2013	2014	2015	2016	2017
Program revenues:										
Charges for services										
General government	\$ 618,514	\$ 483,471	\$ 551,319	\$ 565,523	\$ 578,665	\$ 824,690	\$ 694,869	\$ 796,582	\$ 658,301	\$ 898,000
Security of persons and property	1,000,487	1,350,977	1,262,634	922,977	991,409	721,429	1,257,395	1,225,940	1,315,914	1,197,804
Public health and welfare	6,375	25,956	20,622	18,294	16,413	16,966	5,229	190	220	130
Transportation	-	46,222	13,218	-	-	9,028	4,266	4,706	3,000	1,000
Leisure time activities	551,417	603,543	589,582	543,853	504,117	459,719	312,411	244,830	241,017	311,662
Community development	1,246,241	1,313,937	1,257,755	1,310,136	1,352,244	1,357,232	1,350,029	1,477,072	1,395,370	1,435,498
Public works	-	109,097	26,060	4,749	-	-	-	-	-	16,462
Total charges for services	<u>3,423,034</u>	<u>3,933,203</u>	<u>3,721,190</u>	<u>3,365,532</u>	<u>3,442,848</u>	<u>3,389,064</u>	<u>3,624,199</u>	<u>3,749,320</u>	<u>3,613,822</u>	<u>3,860,556</u>
Operating grants and contributions										
General government	-	-	9,000	7,035	58,103	10,292	21,137	37,576	27,842	-
Security of persons and property	21,103	3,004	35,846	16,893	12,899	119,180	48,522	98,194	77,796	33,690
Public health and welfare	-	-	-	-	-	-	-	-	-	-
Transportation	973,759	949,509	949,074	937,085	948,382	920,547	897,051	950,483	889,600	891,305
Leisure time activities	-	-	-	-	-	12,000	-	-	-	5,000
Community development	-	-	-	-	-	-	3,360	25,744	290,153	-
Public works	-	-	-	-	-	23,764	24,751	32,358	2,121	-
Total operating grants and contributions	<u>994,862</u>	<u>952,513</u>	<u>993,920</u>	<u>961,013</u>	<u>1,019,384</u>	<u>1,085,783</u>	<u>994,821</u>	<u>1,144,355</u>	<u>1,287,512</u>	<u>929,995</u>
Capital grants and contributions										
General government	34,842	-	-	185,500	-	-	1,420,975	58,288	-	30,140
Security of persons and property	1,749	103,500	3,000	117,755	7,968	-	-	-	-	-
Transportation	5,370,901	1,156,966	-	1,267,992	1,938,948	5,971	95,581	-	-	2,429,074
Leisure time activities	-	-	35,000	-	-	-	-	-	-	-
Community development	65,645	-	-	306,298	29,713	-	150,000	-	-	-
Public works	-	183,223	3,958,586	-	-	59,447	476,965	1,283,315	585,456	291,844
Total capital grants and contributions	<u>5,473,137</u>	<u>1,443,689</u>	<u>3,996,586</u>	<u>1,877,545</u>	<u>1,976,629</u>	<u>65,418</u>	<u>2,143,521</u>	<u>1,341,603</u>	<u>585,456</u>	<u>2,751,058</u>
Total program revenues	<u>9,891,033</u>	<u>6,329,405</u>	<u>8,711,696</u>	<u>6,204,090</u>	<u>6,438,861</u>	<u>4,540,265</u>	<u>6,762,541</u>	<u>6,235,278</u>	<u>5,486,790</u>	<u>7,541,609</u>

City of Brook Park, Ohio
Changes in Net Position (continued)
Accrual Basis of Accounting
Last Ten Fiscal Years

Table 2

	2008	2009	2010	2011	2012	2013	2014	2015	2016	2017
Expenses:										
General government	5,319,134	5,200,887	4,979,667	5,047,013	5,957,703	4,614,338	4,902,511	4,548,339	4,756,377	4,432,813
Security of persons and property	11,325,203	12,524,620	12,160,835	11,430,668	11,068,045	11,287,480	10,985,542	10,659,035	12,063,794	12,555,307
Public health and welfare	483,130	393,134	542,592	412,809	314,932	313,017	278,394	230,016	209,629	247,059
Transportation	2,766,466	2,504,805	2,613,821	2,486,308	3,213,847	3,083,726	3,210,908	3,081,564	2,946,070	3,610,372
Leisure time activities	2,866,895	2,818,681	2,581,318	2,562,792	2,305,024	2,198,184	2,095,119	1,508,908	1,567,408	1,752,451
Community development	2,701,221	1,507,000	1,790,631	1,428,069	1,035,202	886,092	1,088,706	1,160,879	1,637,055	1,371,587
Public works	4,351,316	4,308,772	3,537,459	3,547,146	3,501,691	3,230,274	3,218,651	3,080,342	3,228,252	4,130,367
Interest and fiscal charges	54,951	47,563	44,829	46,100	98,982	264,510	284,964	230,077	238,212	512,537
Total primary government expenses	<u>29,868,316</u>	<u>29,305,462</u>	<u>28,251,152</u>	<u>26,960,905</u>	<u>27,495,426</u>	<u>25,877,621</u>	<u>26,064,795</u>	<u>24,499,160</u>	<u>26,646,797</u>	<u>28,612,493</u>
Net (expense)/revenue	<u>(19,977,283)</u>	<u>(22,976,057)</u>	<u>(19,539,456)</u>	<u>(20,756,815)</u>	<u>(21,056,565)</u>	<u>(21,337,356)</u>	<u>(19,302,254)</u>	<u>(18,263,882)</u>	<u>(21,160,007)</u>	<u>(21,070,884)</u>
General revenues										
Property taxes	2,331,911	2,134,450	2,026,186	1,994,242	1,986,778	1,807,889	1,684,574	1,769,793	1,836,353	1,852,018
Municipal income taxes	18,358,018	17,343,214	17,029,564	17,801,257	17,768,862	18,134,634	18,556,361	19,570,562	19,608,280	19,774,881
Grants and entitlements										
not restricted to specific programs	2,087,153	1,944,138	2,016,732	1,393,561	878,135	615,425	790,071	716,253	618,590	600,624
Investment income	686,197	150,111	29,733	4,702	7,157	2,045	4,746	19,345	62,985	112,037
All other revenues	30	-	4,603	2,428	57,328	76,097	65,244	1,265	16,088	24,845
Total general revenues	<u>23,463,309</u>	<u>21,571,913</u>	<u>21,106,818</u>	<u>21,196,190</u>	<u>20,698,260</u>	<u>20,636,090</u>	<u>21,100,996</u>	<u>22,077,218</u>	<u>22,142,296</u>	<u>22,364,405</u>
Change in net position	<u>\$ 3,486,026</u>	<u>\$ (1,404,144)</u>	<u>\$ 1,567,362</u>	<u>\$ 439,375</u>	<u>\$ (358,305)</u>	<u>\$ (701,266)</u>	<u>\$ 1,798,742</u>	<u>\$ 3,813,336</u>	<u>\$ 982,289</u>	<u>\$ 1,293,521</u>

City of Brook Park, Ohio
Fund Balances, Governmental Funds
Modified Accrual Basis of Accounting
Last Ten Fiscal Years

Table 3

	2008	2009	2010	2011	2012	2013	2014	2015	2016	2017
General fund:										
Nonspendable	\$ -	\$ -	\$ 370,218	\$ 283,312	\$ 266,001	\$ 261,923	\$ 273,738	\$ 295,958	\$ 333,786	\$ 236,118
Committed	-	-	3,763,449	3,229,970	2,767,778	1,874,885	1,481,623	1,661,168	1,987,936	2,251,239
Assigned	-	-	1,109,427	414,414	277,395	266,035	250,794	216,578	2,639,376	404,642
Unassigned	-	-	684,449	1,415,476	3,064,486	3,070,287	3,375,377	6,697,552	4,787,899	6,028,519
Reserved	561,726	581,663	-	-	-	-	-	-	-	-
Unreserved	4,905,898	3,445,039	-	-	-	-	-	-	-	-
Total general fund	<u>5,467,624</u>	<u>4,026,702</u>	<u>5,927,543</u>	<u>5,343,172</u>	<u>6,375,660</u>	<u>5,473,130</u>	<u>5,381,532</u>	<u>8,871,256</u>	<u>9,748,997</u>	<u>8,920,518</u>
All other governmental funds:										
Nonspendable	-	-	-	-	-	-	-	-	-	392
Restricted	-	-	3,793,076	4,316,404	3,980,814	6,967,254	6,231,265	5,247,066	4,026,978	5,307,204
Committed	-	-	3,747,047	3,568,496	2,246,761	4,091,320	4,055,013	3,957,344	4,336,381	4,452,527
Assigned	-	-	2,669,474	2,639,466	1,757,135	859,276	891,596	891,596	1,128,496	1,105,049
Unassigned (Deficit)	-	-	(455,619)	(445,746)	(354,414)	(102,722)	(153,258)	(27,198)	(66,984)	-
Reserved	3,897,002	2,354,819	-	-	-	-	-	-	-	-
Unreserved:										
Designated:										
Accrued retiree benefits	1,049,591	1,534,236	-	-	-	-	-	-	-	-
Undesignated, reported in:										
Special revenue	2,527,419	2,551,083	-	-	-	-	-	-	-	-
Debt service	460,119	493,635	-	-	-	-	-	-	-	-
Capital project	7,272,257	5,770,241	-	-	-	-	-	-	-	-
Total all other governmental funds	<u>15,206,388</u>	<u>12,704,014</u>	<u>9,753,978</u>	<u>10,078,620</u>	<u>7,630,296</u>	<u>11,815,128</u>	<u>11,024,616</u>	<u>10,068,808</u>	<u>9,424,871</u>	<u>10,865,172</u>
Total governmental funds	<u>\$ 20,674,012</u>	<u>\$ 16,730,716</u>	<u>\$ 15,681,521</u>	<u>\$ 15,421,792</u>	<u>\$ 14,005,956</u>	<u>\$ 17,288,258</u>	<u>\$ 16,406,148</u>	<u>\$ 18,940,064</u>	<u>\$ 19,173,868</u>	<u>\$ 19,785,690</u>

Note: In 2011, the City implemented GASB Statement No. 54. As a result, the 2010 fund balances were reclassified to reflect the effects of GASB Statement No.54.

City of Brook Park, Ohio

Changes in Fund Balances, Governmental Funds

Modified Accrual Basis of Accounting

Last Ten Fiscal Years

Table 4

	2008	2009	2010	2011	2012	2013	2014	2015	2016	2017
Revenues:										
Property Taxes	\$ 2,338,903	\$ 2,223,343	\$ 2,031,983	\$ 2,002,050	\$ 1,952,842	\$ 1,827,212	\$ 1,735,105	\$ 1,777,005	\$ 1,832,246	\$ 1,854,778
Income Taxes	17,999,769	16,863,883	16,959,103	17,465,889	17,603,699	17,577,172	18,097,977	19,271,134	19,055,491	19,436,285
Other Taxes	358,969	274,922	271,452	325,486	213,567	338,001	345,238	344,687	375,180	294,893
Intergovernmental	8,224,555	4,553,194	6,508,356	3,772,270	3,537,753	1,861,096	3,952,536	2,969,726	2,177,933	4,243,934
Interest	684,229	240,545	33,181	4,893	7,172	2,045	4,746	19,345	62,985	112,067
Licenses and Permits	465,318	411,410	547,492	705,694	689,562	739,328	699,901	855,440	751,259	642,082
Fines and Forfeitures	358,033	294,582	531,713	350,017	408,470	268,370	535,859	851,371	715,504	707,177
Rentals	2,775	3,000	2,500	1,975	3,550	3,850	1,650	87,998	90,176	53,299
Charges for Services	1,979,578	2,273,175	2,360,691	1,984,816	1,867,450	1,785,589	1,773,668	1,688,949	1,662,569	1,763,713
Contributions and Donations	18,307	22,176	15,208	219,725	190,820	91,648	72,075	35,724	38,735	1,825
Special Assessments	83,419	84,655	82,933	85,071	85,066	85,512	82,455	82,987	63,354	60,216
All Other Revenues	599,053	521,282	478,617	700,243	471,719	722,235	443,236	472,446	676,328	646,469
Total Revenues	33,112,908	27,766,167	29,823,229	27,618,129	27,031,670	25,302,058	27,744,446	28,456,812	27,501,760	29,816,738
Expenditures:										
Current:										
Security of persons and property	11,984,162	11,981,074	11,588,747	11,540,053	11,014,188	11,017,683	10,799,690	10,162,731	10,775,343	11,049,682
Public health and welfare	490,831	404,083	433,317	408,973	309,741	307,431	272,808	218,934	203,908	234,788
Leisure time activities	2,532,652	2,418,962	2,176,888	2,243,478	2,031,832	1,878,129	1,841,553	1,196,974	1,264,030	1,266,269
Community development	2,710,605	1,758,463	1,168,046	1,942,284	1,037,516	895,478	1,372,890	1,149,580	1,673,383	1,218,055
Public works	3,891,294	3,600,960	2,942,100	3,052,788	2,820,750	2,456,099	2,795,928	2,275,222	2,492,120	2,391,617
Transportation	2,014,481	1,593,031	1,560,812	1,643,494	4,243,551	2,427,129	1,250,950	1,212,767	1,310,713	1,903,259
General government	5,263,908	5,100,208	4,826,362	4,791,064	5,556,723	6,957,185	5,589,126	4,546,852	4,624,175	3,747,761
Capital Outlay	10,833,340	5,437,258	5,420,568	3,648,548	2,968,253	1,270,804	3,985,506	5,578,459	4,146,644	12,707,301
Debt Service:										
Principal retirement	170,000	175,000	228,733	287,467	388,374	398,374	608,374	764,579	541,847	1,372,623
Interest and fiscal charges	62,625	58,375	53,477	48,075	90,704	84,467	314,141	282,883	257,212	350,414
Bond issuance costs	-	-	-	64,143	2,491	115,166	-	-	-	160,098
Total expenditures	39,953,898	32,527,414	30,399,050	29,670,367	30,464,123	27,807,945	28,830,966	27,388,981	27,289,375	36,401,867
Excess of revenues over (under) expenditures	(6,840,990)	(4,761,247)	(575,821)	(2,052,238)	(3,432,453)	(2,505,887)	(1,086,520)	1,067,831	212,385	(6,585,129)

City of Brook Park, Ohio

Changes in Fund Balances, Governmental Funds (continued)

Modified Accrual Basis of Accounting

Last Ten Fiscal Years

Table 4

	2008	2009	2010	2011	2012	2013	2014	2015	2016	2017
Other financing sources (uses):										
General Obligation Bond issued	-	-	-	1,705,000	-	5,520,000	-	-	-	4,980,000
OWDA Loan issued	-	339,187	-	-	-	-	-	-	-	-
OPWC loans issued	1,678,203	271,129	92,896	25,243	-	-	-	1,429,520	19,611	-
Premium on Debt issuance	-	-	-	25,873	-	253,973	-	-	-	219,628
Capital leases	650,985	157,445	-	-	2,006,371	-	150,879	-	-	1,997,323
Sale of capital assets	12,573	50,190	8,660	36,393	10,246	14,216	53,531	36,565	1,808	-
Transfers in	1,209,598	2,313,639	3,423,113	1,390,040	3,534,965	2,817,504	2,010,532	3,726,485	3,757,891	5,227,068
Transfers out	(1,209,598)	(2,313,639)	(3,423,113)	(1,390,040)	(3,534,965)	(2,817,504)	(2,010,532)	(3,726,485)	(3,757,891)	(5,227,068)
Total other financing sources (uses)	2,341,761	817,951	101,556	1,792,509	2,016,617	5,788,189	204,410	1,466,085	21,419	7,196,951
Net change in fund balances	\$ (4,499,229)	\$ (3,943,296)	\$ (474,265)	\$ (259,729)	\$ (1,415,836)	\$ 3,282,302	\$ (882,110)	\$ 2,533,916	\$ 233,804	\$ 611,822
Debt service as a percentage of noncapital expenditures	0.79%	0.85%	1.11%	1.29%	1.88%	1.97%	3.73%	4.77%	3.39%	7.12%

City of Brook Park, Ohio

Assessed Valuations and Estimated True Values

Last Ten Years

Table 5

<u>Collection Year</u>	<u>Residential/ Agricultural Real Property</u>	<u>Other Real Property</u>	<u>Public Utility Tangible</u>	<u>Tangible Personal Property</u>	<u>Total</u>	<u>Estimated True Value of Real Property</u>	<u>Direct Tax Rate</u>
2008	\$ 314,329,200	\$ 142,446,360	\$ 8,447,320	\$ 58,744,121	\$ 523,967,001	\$ 1,305,073,029	\$ 4.75
2009	315,453,260	169,275,580	8,664,680	29,901,423	523,294,943	1,384,939,543	4.75
2010	290,810,300	148,270,160	9,019,390	-	448,099,850	1,254,515,600	4.75
2011	291,898,930	171,886,210	9,310,360	-	473,095,500	1,325,100,400	4.75
2012	291,695,680	171,577,480	9,584,670	-	472,857,830	1,323,637,600	4.75
2013	256,589,630	153,158,610	10,334,750	-	420,082,990	1,170,709,257	4.75
2014	256,527,620	153,604,430	11,308,840	-	421,440,890	1,171,805,857	4.75
2015	256,334,940	149,203,660	11,718,840	-	417,257,440	1,158,681,714	4.75
2016	250,842,440	146,587,480	11,850,930	-	409,280,850	1,135,514,057	4.75
2017	250,821,870	147,770,180	12,450,870	-	411,042,920	1,138,834,429	4.75

Source: Cuyahoga County Fiscal Officer

Note: In Collection Year 2010, tangible personal property taxes were completely phased out. Therefore, this tax will no longer be levied.

City of Brook Park, Ohio

Property Tax Rates – Direct and Overlapping Governments (Per \$1,000 of Assessed Valuation)

Last Ten Years

Table 6

Collection Year	City of Brook Park			Berea City School District	Polaris Vocational School	Cuyahoga County Commissioners	Special (2) Taxing Districts	Total Tax Levy
	General Fund	Special Funds (1)	Total Levy					
2008	\$ 3.85	\$ 0.90	\$ 4.75	\$ 74.90	\$ 2.40	\$ 13.42	\$ 6.78	\$ 102.25
2009	3.85	0.90	4.75	74.90	2.40	13.32	7.28	102.65
2010	3.85	0.90	4.75	74.90	2.40	13.32	7.58	102.95
2011	3.85	0.90	4.75	75.00	2.40	13.22	7.58	102.95
2012	3.85	0.90	4.75	78.90	2.40	13.22	7.58	106.85
2013	3.85	0.90	4.75	78.90	2.40	13.22	7.58	106.85
2014	3.85	0.90	4.75	78.80	2.40	14.05	8.48	108.48
2015	3.85	0.90	4.75	78.00	2.40	14.05	9.38	108.58
2016	3.85	0.90	4.75	82.20	3.09	14.05	9.38	113.47
2017	3.85	0.90	4.75	82.20	3.09	14.05	9.88	113.97

Source: Cuyahoga County Fiscal Officer

(1) – Southwest General Hospital, Police & Firemen Pension Fund, and Tri City Senior Center. Tri City Senior Center was not renewed in 2007 and is excluded after the 2006 rate.

(2) – Metroparks, Port Authority, County Library, Community College

City of Brook Park, Ohio
Real Property Tax Levies And Collections
Last Ten Years

Table 7a

<u>Year</u>	<u>Current Tax Levy</u>	<u>Current Collections</u>	<u>Percentage of Current Collections To Current Levy</u>	<u>Prior Year Collections</u>	<u>Total Collections (1)</u>	<u>Percentage of Total Collections To Current Levy</u>
2008	\$ 2,293,775	\$ 2,222,011	97%	\$ 77,522	\$ 2,299,533	100%
2009	2,310,821	2,234,522	97%	51,048	2,285,570	99%
2010	2,199,507	2,134,591	97%	65,000	2,199,591	100%
2011	2,219,407	2,114,938	95%	71,669	2,186,607	99%
2012	2,225,730	2,072,366	93%	73,996	2,146,362	96%
2013	1,998,706	1,908,141	95%	59,236	1,967,377	98%
2014	1,985,143	1,802,931	91%	66,265	1,869,196	94%
2015	1,968,424	1,847,043	94%	31,346	1,878,389	95%
2016	1,937,631	1,840,233	95%	45,838	1,886,071	97%
2017	1,960,980	1,905,677	97%	50,368	1,956,045	100%

Source: Cuyahoga County Fiscal Officer

(1) State reimbursement of rollback and homestead exemptions is included

Note: The County is aware of the requirement to report delinquent tax collections by levy year rather than by collection year. The County's current computer system tracks levy amounts by either current levy or delinquent levy. Once amounts become part of the delinquent levy, the ability to track information by levy year is lost. The County is looking at options to provide this information in the future.

City of Brook Park, Ohio

Tangible Personal Property Tax Levies And Collections

Last Ten Years

Table 7b

<u>Year</u>	<u>Current Tax Levy</u>	<u>Current Collections</u>	<u>Percentage of Current Collections To Current Levy</u>	<u>Prior Year Collections</u>	<u>Total Collections</u>	<u>Percentage of Total Collections To Current Levy</u>
2008	\$ 139,575	\$ 139,418	100%	\$ 16,815	\$ 156,233	112%
2009	5,822	5,819	100%	24,757	30,576	525%
2010	3,070	3,070	100%	-	3,070	100%
2011	-	-	0%	984	984	0%
2012	-	-	0%	152	152	0%
2013	-	-	0%	67	67	0%
2014	-	-	0%	-	-	0%
2015	-	-	0%	-	-	0%
2016	-	-	0%	-	-	0%
2017	-	-	0%	-	-	0%

Source: Cuyahoga County Fiscal Officer

Note: In 2010, tangible personal property taxes were completely phased out. Therefore, this tax will no longer be levied. Refer to the Note provided in Table 7a which provides an explanation for the percentages of total collections exceeding the current levies.

City of Brook Park, Ohio
Principal Taxpayers - Real Estate Tax
2017 and 2008

Table 8

Name of Taxpayer	December 31, 2017	
	Assessed Value (1) (2)	Percent of Total Assessed Value
Cleveland Electric Illum Co	\$ 10,185,680	2.56%
M.W.P. Company	8,138,670	2.04%
CP-Snow Prop, LLC	5,815,260	1.46%
Ford Motor Engine Plt.	5,250,000	1.32%
Laich, Walter	4,615,380	1.16%
Brook Park Station, LLC	3,549,010	0.89%
CP-Cleveland ADC, LLC and Chavez	3,227,460	0.81%
Ford Motor Co.	2,940,010	0.74%
Techpark Ltd Partnership	2,938,680	0.74%
Cambridge Brook Park II LLC	2,625,010	0.66%
Total	<u>\$ 49,285,160</u>	<u>12.38%</u>
Total Assessed Valuation	<u>398,592,050</u>	

Name of Taxpayer	December 31, 2008	
	Assessed Value (1) (2)	Percent of Total Assessed Value
Ford Motor Company	\$ 19,387,250	3.76%
M.W.P. Company	9,857,350	1.91%
Cleveland Electric Illuminating	7,243,190	1.41%
Tech Park Limited Partnership	7,241,740	1.40%
Laich, Walter	6,475,000	1.26%
Albrecht Inc.	5,207,690	1.01%
CP-Snow Prop, LLC	4,683,210	0.91%
Brookgate Associates, LLC	4,200,020	0.81%
CP-Cleveland ADC, LLC	3,739,300	0.73%
Foseco Metallurgical Inc.	2,291,630	0.44%
Total	<u>\$ 70,326,380</u>	<u>13.64%</u>
Total Assessed Valuation	<u>515,519,681</u>	

Source: Cuyahoga County Fiscal Officer

(1) Excludes Public Utilities

(2) The amounts presented represent the assessed values upon which 2017 collections were based.

City of Brook Park, Ohio

Municipal Income Tax Revenues By Source

Modified Accrual Basis of Accounting

Last Ten Years**Table 9**

<u>Withheld Year</u>	<u>Individual Tax</u>	<u>Municipal Direct Tax</u>	<u>Business Direct Tax</u>	<u>Income Tax Collections</u>
2008	\$ 16,200,253	\$ 655,380	\$ 1,144,136	\$ 17,999,769
2009	14,835,940	688,482	1,339,461	16,863,883
2010	14,904,762	610,161	1,444,180	16,959,103
2011	15,407,196	754,473	1,304,220	17,465,889
2012	15,348,105	681,180	1,574,414	17,603,699
2013	15,290,038	708,829	1,578,305	17,577,172
2014	15,607,541	693,255	1,797,181	18,097,977
2015	16,689,291	861,607	1,720,236	19,271,134
2016	16,601,871	854,375	1,599,245	19,055,491
2017	16,751,040	871,010	1,857,938	19,479,988

Source: City Financial Records

City of Brook Park, Ohio

Ratio of Outstanding Debt to Total Personal Income and Debt per Capita

Last Ten Years

Table 10

Fiscal Year	Governmental Activities					Total	Percentage of Personal Income	Per Capita
	General Obligation Bonds (1)	General Obligation Notes (1)	OPWC Loans	OWDA Loan	Lease Purchase Agreements			
2008	1,605,000	-	1,678,203	-	1,142,044	4,425,247	1.02%	209
2009	1,430,000	-	1,949,332	339,187	650,507	4,369,026	1.01%	206
2010	1,250,000	-	1,993,495	-	222,556	3,466,051	0.75%	180
2011	2,765,000	-	1,921,271	-	2,403	4,688,674	1.02%	244
2012	2,480,000	750,000	1,817,897	-	1,616,919	6,664,816	1.45%	347
2013	7,977,641	-	1,714,523	-	1,253,966	10,946,130	2.38%	570
2014	7,456,470	-	1,611,149	-	984,644	10,052,263	2.19%	523
2015	7,060,299	-	2,921,137	-	719,597	10,701,033	2.33%	557
2016	6,654,127	-	2,788,901	-	449,965	9,892,993	2.15%	515
2017	11,340,263	-	2,633,141	-	1,720,425	15,693,829	3.41%	817

(1) – Amounts include associated premiums

Source: City Financial Records

- Population and Personal Income data are presented on Table 15
- The OPWC Loans are in the City's name; however, \$760,240 of the total outstanding at December 31, 2016 will be reimbursed by the City of Cleveland.
- The funding structure of the OWDA Loan was changed from a loan to grant during 2010. Therefore, the City is no longer required to repay the \$339,187.

City of Brook Park, Ohio

Ratio of Net General Bonded Debt to Assessed Value and Net Bonded Debt Per Capita

Last Ten Years

Table 11

Year	Gross Bonded Debt (1)	Accumulated Resources Restricted For Repayment	Net General Bonded Debt	Assessed Value (3)	Population (2)	Ratio of Net Bonded Debt to Assessed Value	Debt per Capita
2008	1,605,000	(541,282)	1,063,718	523,967,001	21,218	0.20%	50.13
2009	1,430,000	(574,620)	855,380	523,294,943	21,218	0.16%	40.31
2010	1,250,000	(651,203)	598,797	448,099,850	19,212	0.13%	31.17
2011	2,765,000	(634,751)	2,130,249	473,095,500	19,212	0.45%	110.88
2012	2,480,000	(730,029)	1,749,971	472,857,830	19,212	0.37%	91.09
2013	7,977,641	(747,956)	7,229,685	420,082,990	19,212	1.72%	376.31
2014	7,456,470	(803,224)	6,653,246	421,440,890	19,212	1.58%	346.31
2015	7,060,299	(3,994,770)	3,065,529	417,257,440	19,212	0.73%	159.56
2016	6,654,127	(3,726,530)	2,927,597	409,280,850	19,212	0.72%	152.38
2017	11,340,263	(1,162,932)	10,177,331	411,042,920	19,212	2.48%	529.74

(1) Includes all general obligation bonded debt and unamortized premiums.

(2) Source: 2000 and 2010 U.S. Census

(3) Office of the County Fiscal Officer, Cuyahoga County, Ohio

City of Brook Park, Ohio
Computation of Direct and Overlapping Debt
December 31, 2017

Table 12

<u>Jurisdiction</u>	<u>Net Debt Outstanding</u>	(1) <u>Percentage Applicable to City of Brook Park</u>	<u>Amount Applicable to City of Brook Park</u>
Direct Debt:			
City of Brook Park (2)			
General Obligation Bonds	\$ 11,340,263	100.00%	\$ 11,340,263
OPWC Loan	2,633,141	100.00%	2,633,141
Capital Leases	1,720,425	100.00%	1,720,425
Total Direct Debt	15,693,829		15,693,829
Overlapping Debt:			
Berea City School District	112,195,000	1.47%	1,653,892
Cleveland City School District	250,377,647	0.23%	566,541
Cuyahoga County	207,485,000	1.62%	3,364,232
Regional Transit Authority	1,995,000	2.92%	58,181
Total Overlapping Debt	572,052,647		5,642,846
Total	\$ 587,746,476		\$ 21,336,675

Source: Cuyahoga County Fiscal Officer

(1) Percentages determined by dividing each overlapping subdivision's assessed valuation within the City by the subdivision's total assessed valuation.

(2) Amounts include associated premiums.

City of Brook Park, Ohio

Legal Debt Margin

Last Ten Fiscal Years

Table 13

	2008	2009	2010	2011	2012	2013	2014	2015	2016	2017
Assessed Valuation	\$ 523,967,001	\$ 523,294,943	\$ 448,099,850	\$ 473,095,500	\$ 472,857,830	\$ 420,082,990	\$ 421,440,890	\$ 417,257,440	\$ 409,280,850	\$ 411,042,920
Overall debt limit - 10.5% of assessed value	55,016,535	54,945,969	47,050,484	49,675,028	49,650,072	44,108,714	44,251,293	43,812,031	42,974,489	43,159,507
Gross indebtedness	1,605,000	1,430,000	3,466,051	4,686,271	5,047,897	9,692,164	9,067,619	9,981,436	9,443,028	13,973,404
Less: debt outside limitation	-	-	(1,235,389)	(1,140,359)	(1,077,005)	(1,013,652)	(950,299)	(886,946)	(823,593)	(760,240)
Less: amount available in debt service fund	(460,119)	(493,635)	(1,802,168)	(1,757,346)	(1,725,522)	(1,901,974)	(1,872,159)	(1,805,318)	(2,111,431)	(1,895,640)
Net debt within 10.5% limit	1,144,881	936,365	428,494	1,788,566	2,245,370	6,776,538	6,245,161	7,289,172	6,508,004	11,317,524
Legal Debt Margin	\$ 53,871,654	\$ 54,009,604	\$ 46,621,990	\$ 47,886,462	\$ 47,404,702	\$ 37,332,176	\$ 38,006,132	\$ 36,522,859	\$ 36,466,485	\$ 31,841,983
Debt Limit - 5.5% of assessed unvoted value	\$ 28,818,185	\$ 28,781,222	\$ 24,645,492	\$ 26,020,253	\$ 26,007,181	\$ 23,104,564	\$ 23,179,249	\$ 22,949,159	\$ 22,510,447	\$ 22,607,361
Gross indebtedness authorized by council:	1,605,000	1,430,000	3,466,051	4,686,271	4,686,271	9,692,164	9,067,619	9,981,436	9,443,028	13,973,404
Less: debt outside limitation	-	-	(1,235,389)	(1,140,359)	(1,077,005)	(1,013,652)	(950,299)	(886,946)	(823,593)	(760,240)
Less: amount available in debt service fund	(460,119)	(493,635)	(1,802,168)	(1,757,346)	(1,725,522)	(1,901,974)	(1,872,159)	(1,805,318)	(2,111,431)	(1,895,640)
Net debt within 5.5% limit	1,144,881	936,365	428,494	1,788,566	1,883,744	6,776,538	6,245,161	7,289,172	6,508,004	11,317,524
Unvoted debt margin	\$ 27,673,304	\$ 27,844,857	\$ 24,216,998	\$ 24,231,687	\$ 24,123,437	\$ 16,328,026	\$ 16,934,088	\$ 15,659,987	\$ 16,002,443	\$ 11,289,837

Source: Cuyahoga County Fiscal Officer and City Financial Records

City of Brook Park, Ohio

Principal Employers

Current Year and 2008

Table 14

<u>Employer</u>	2017	
	<u>Employees</u>	<u>Percentage of</u>
Department of the Interior	1,649	7.20%
Ford Motor Company	1,599	6.99%
Day Star Staffing (Malley's)	798	3.49%
Marc Glassman Inc.	641	2.80%
Group Management Services	457	2.00%
Credit First National	411	1.80%
City of Brook Park	312	1.36%
Lakefront Lines Inc.	276	1.21%
Alycon Technical	254	1.11%
Global Payment Holding	253	1.11%
Total	<u>6,650</u>	<u>29.07%</u>
Total City Employment	<u><u>22,889</u></u>	<u><u>100.00%</u></u>

<u>Employer</u>	2008	
	<u>Employees</u>	<u>Percentage of</u>
Ford Motor Company	1,651	7.65%
Department of the Interior	1,512	7.01%
Marc Glassman Inc.	633	2.93%
National City Corporation	499	2.31%
City of Brook Park	392	1.82%
Berea City School District	310	1.44%
Foseco Metallurgical Inc.	279	1.29%
SGT Inc.	192	0.89%
BGS Retail	133	0.62%
Sierra Lobo Inc.	108	0.50%
Total	<u>5,709</u>	<u>26.46%</u>
Total City Employment	<u><u>21,574</u></u>	<u><u>100.00%</u></u>

Source: City Income Tax Department.

City of Brook Park, Ohio
Demographic and Economic Statistics
Last Ten Years

Table 15

Year	Population (1)	Total Personal Income (4)	Personal Income Per Capita (1)	Median Household Income (1)	Median Age (1)	School Enrollment (2)	Cuyahoga County Unemployment Rate (3)
2008	21,218	\$ 433,080,598	\$ 20,411	\$ 46,333	39.8	7,157	7.1%
2009	21,218	433,080,598	20,411	46,333	39.8	7,181	8.9%
2010	19,212	459,704,736	23,928	53,264	43.8	7,099	9.5%
2011	19,212	459,704,736	23,928	53,264	43.8	7,017	7.1%
2012	19,212	459,704,736	23,928	53,264	43.8	7,122	6.6%
2013	19,212	459,704,736	23,928	53,264	43.8	6,681	7.2%
2014	19,212	459,704,736	23,928	53,264	43.8	6,361	5.3%
2015	19,212	459,704,736	23,928	53,264	43.8	6,491	5.5%
2016	19,212	459,704,736	23,928	53,264	43.8	6,537	5.5%
2017	19,212	459,704,736	23,928	53,264	43.8	6,379	5.6%

(1) Source: 2000 and 2010 U. S. Census

(2) Source: Ohio Department of Education Website

(3) Source: Ohio Bureau of Employment Services, U.S. Department of Labor, Bureau of Labor Statistics for Cleveland

(4) Computation of per capita personal income multiplied by population

City of Brook Park, Ohio
Full Time Employees by Function/Program
Last Ten Years

Table 16

	2008	2009 (1)	2010	2011	2012	2013	2014	2015	2016	2017
Function/program:										
General government:										
Council	2.00	2.00	2.00	2.00	1.50	1.00	1.00	1.00	1.00	1.00
Finance	5.00	5.00	4.00	4.00	4.00	4.00	4.00	4.00	4.00	4.00
Tax	6.00	4.50	4.00	3.00	3.50	3.00	3.00	3.00	3.00	3.00
Law	2.00	2.00	2.00	1.00	1.50	1.00	1.00	1.00	1.00	2.00
Mayor's office	3.00	2.00	2.00	2.00	2.00	3.00	2.00	2.00	3.00	3.00
Human resources	1.00	1.00	1.00	1.00	1.00	1.00	1.00	1.00	1.00	1.00
Civil service	1.00	0.50	0.50	-	0.50	-	0.50	0.50	0.50	0.50
Clerk of courts	1.00	1.00	1.00	1.00	1.00	1.00	1.00	1.00	1.00	1.00
Security of persons and property:										
Safety department	11.00	10.00	11.00	9.00	9.00	11.00	8.00	6.00	6.00	3.00
Animal warden	2.00	2.00	1.00	1.00	1.50	1.00	1.50	1.50	1.50	1.50
Police	44.00	44.00	43.00	39.00	39.00	41.00	38.00	36.00	36.00	36.00
Police administration	2.00	1.00	1.00	1.00	1.00	1.00	1.00	1.00	1.00	1.00
Property maintenance	5.00	3.50	4.00	4.00	3.00	4.00	4.00	3.00	3.00	4.00
Fire	40.00	42.00	37.00	34.00	34.00	36.00	33.00	30.00	30.00	30.00
Fire administration	1.00	1.00	1.00	1.00	-	-	-	-	-	-
Public health and welfare:										
Office of aging	3.00	2.50	2.50	2.50	1.50	-	-	-	-	-
Leisure time activities:										
Recreation	8.00	9.00	7.50	7.00	6.00	6.00	7.00	6.00	5.00	5.00
Community development:										
Building	6.00	6.00	6.00	5.00	4.00	4.00	5.00	5.00	5.00	5.50
Economic development	1.00	1.00	1.00	1.00	1.00	1.00	1.00	1.00	1.00	1.00
Transportation:										
Service	53.00	50.50	43.50	43.00	40.50	36.00	39.00	31.00	36.00	36
Public works:										
Service	5.00	5.00	5.00	4.00	3.00	3.00	1.00	1.00	1.00	1
Service dispatch	1.00	1.00	1.00	1.00	1.00	1.00	1.00	1.00	1.00	1
Totals	<u>203.00</u>	<u>196.50</u>	<u>181.00</u>	<u>166.50</u>	<u>159.50</u>	<u>159.00</u>	<u>153.00</u>	<u>136.00</u>	<u>141.00</u>	<u>140.50</u>

Source: City Payroll Records

(1) Starting in 2009, the City is reflecting permanent part-time employees as .5 persons

City of Brook Park, Ohio
Operating Indicators by Function/Program
Last Ten Years

Table 17

	2008	2009	2010	2011	2012	2013	2014	2015	2016	2017
Function/program:										
General government:										
Council and clerk										
Number of ordinances passed	110	87	55	66	60	55	75	44	67	40
Number of resolutions passed	37	24	21	27	40	27	24	26	37	29
Finance department:										
Number of checks/vouchers issued (excluding payroll)	5,891	5,666	5,115	5,016	4,877	4,444	4,260	3,893	3,617	3,282
Number of purchase orders issued	1,865	1,507	1,349	1,344	1,320	1,226	1,151	1,035	1,037	995
Number of W-2 forms issued	382	385	351	335	348	377	374	322	302	276
City W-2 wages (in millions)	12	14	14	13	13	12	12	12	11	12
Agency ratings - Fitch	AA-3	AA-3	AA	AA	AA	AA-	AA-	AA-	AA-	AA-
Income tax department:										
Number of individual returns	10,427	10,256	10,572	10,379	10,022	9,970	9,984	10,085	10,473	10,398
Number of business returns	1,682	1,615	1,668	1,659	1,758	1,779	1,810	1,922	1,820	1,800
Number of business withholding accounts	1,580	1,561	1,591	1,476	1,552	1,480	1,554	1,568	1,553	1,581
Civil service:										
Number of exams given	3	1	2	6	4	5	2	1	2	1
Building department										
Number of permits issued	1,257	1,331	1,439	1,401	1,330	1,408	1,392	1,510	1,309	1,314
Security of persons and property:										
Police:										
Number of traffic citations issued	4,197	3,463	2,853	2,203	2,389	2,338	4,900	7,959	5,886	6,258
Number of parking citations issued	1,844	1,444	2,125	2,197	2,412	1,619	1,850	2,279	2,257	2,479
Number of criminal arrests	462	531	814	1,078	928	731	684	707	487	646
Animal warden service calls responded to per annual report	127	163	187	129	768	1,209	1,171	1,095	1,177	1,244

City of Brook Park, Ohio

Operating Indicators by Function/Program (continued)

Last Ten Years

Table 17

	2008	2009	2010	2011	2012	2013	2014	2015	2016	2017
Security of persons and property:										
Fire:										
EMS calls	1,981	2,102	2,190	2,282	2,447	2,204	2,549	2,572	2,639	2,901
Fire and fire-related calls	359	423	418	411	449	423	429	446	440	576
Hydrants tested	1,250	1,250	1,250	1,250	1,250	1,250	1,149	1,206	1,206	1,206
Leisure time activities:										
Recreation:										
Number of memberships	7,961	7,746	4,762	3,968	3,358	2,153	2,653	3,100	3,187	2,767
Community development:										
Parking fees collected due to										
Economic development dept.	\$ 1,061,234	\$ 1,051,743	\$ 995,999	\$ 976,591	\$ 975,500	\$ 968,732	\$ 965,031	\$ 985,439	\$985,758	\$ 987,855
Public works:										
Refuse disposal per year (tons)	9,138	9,858	10,901	10,930	10,870	7,129	7,423	9,483	9,734	8,840
Refuse disposal costs per year	\$ 411,540	\$ 468,255	\$ 386,998	\$ 378,919	\$ 361,016	\$ 272,325	\$ 298,457	\$ 340,659	\$ 357,231	\$ 429,612
Percentage of waste recycled	4.12%	2.41%	2.00%	4.00%	9.00%	10.42%	15.44%	10.00%	12.79%	10.11%
Transportation:										
Snowfall in inches	85.20	85.20	58.40	69.50	38.90	68.10	64.60	60.00	68.00	68.1
Cost of salt purchased	\$ 379,808	\$ 238,218	\$ 222,818	\$ 100,124	\$ 127,428	\$ 167,207	\$ 188,632	\$ 213,392	\$ 201,121	\$ 88,532
Asphalt used in road maintenance										
(tons)	125	425	348	76	272	336	211	283	173	130
Concrete used in road maintenance										
(yards)	300	590	110	244	179	290	161	202	261	245
Number of trees removed	131	98	78	207	175	213	109	84	183	0
Number of trees planted	105	102	80	8	15	100	-	-	-	
Senior citizen driveway plowing										
participants	1,368	1,312	1,210	1,140	1,096	1,149	-	-	-	

Source: Information was provided from the various departments within the City

(2) Information does not include amended returns, voids, etc.

N/A- Information is not available

City of Brook Park, Ohio

Capital Assets Statistics by Function/Program

Last Ten Years

Table 18

	2008	2009	2010	2011	2012	2013	2014	2015	2016	2017
Function/program:										
General government:										
City Hall square footage	16,880	16,880	16,880	16,880	16,880	16,880	16,880	16,880	16,880	16,880
Other departmental vehicles	13	12	12	12	12	12	12	12	12	12
Security of persons and property:										
Police:										
Stations	1	1	1	1	1	1	1	1	1	1
Square footage of Police (and Fire) building	16,072	16,072	16,072	16,072	16,072	16,072	16,072	16,072	16,072	16,072
Number of vehicles	33	33	33	33	41	34	30	30	33	30
Number of street lights	2,565	2,565	2,565	2,565	2,565	2,565	2,565	2,565	2,565	2,565
Number of traffic lights	49	44	44	44	44	44	44	44	44	44
Fire:										
Stations	3	3	3	2	2	2	2	2	2	2
Square footage of station	16,072	16,072	16,072	16,072	16,072	16,072	16,072	16,072	16,072	16,072
Square footage of station - Ruple	3,807	3,807	3,807	3,807	3,807	3,807	3,807	3,807	3,807	3,807
Number of Vehicles	15	15	15	14	14	13	14	14	14	14
Leisure time activities:										
Recreation:										
Number of Parks	7	7	7	7	7	7	7	7	7	7
Number of Pools	2	2	2	2	2	2	2	2	2	2
Number of Diving Tanks	1	1	1	1	1	1	1	1	1	1
Square footage of Recreation Center	105,300	105,300	105,300	105,300	105,300	105,300	105,300	105,300	105,300	105,300
Public works:										
Streets (miles)	46	46	46	46	46	46	46	46	46	46
Service vehicles	74	74	74	74	74	74	74	74	75	75

Source: Information is provided from the City's capital asset records

This page is intentionally left blank.